

VOXI EC

Fixed Electrochemical Gas Detectors

MP840

User's Guide



Contents

- 1. General Information 3**
 - 1.1 Key Features.....3
- 2. User Interface 4**
- 3. Installation 5**
 - 3.1 Mounting5
 - 3.2 Rain Cap6
 - 3.3 Electrical Connections7
 - 3.3.1 Internal Wiring7
 - 3.3.2 Grounding8
 - 3.3.3 Maximum Wiring Length8
 - 3.3.4 Baseline 4 mA Signal Adjustment.....8
 - 3.3.5 MODBUS Message RTU.....9
- 4. Operation 11**
 - 4.1 Standard Operation11
 - 4.2 Programming using Hand-held Remote.....11
 - 4.2.1 Battery Installation11
 - 4.2.2 User Interface.....11
 - 4.2.3 Navigating Menus and Sub-Menus11
 - 4.2.4 Default Settings.....14
 - 4.3 Calibration16
- 5. Maintenance 18**
 - 5.1 Filter Replacement18
 - 5.2 Sensor Replacement.....18
 - 5.3 LCD or Circuit Board Replacement19
- 6. Troubleshooting 20**
 - 6.1 4-20 mA Alarm Signals.....21
- 7. Technical Specifications 22**
- 8. Replacement Parts..... 23**

Read Before Operating

This manual must be carefully read by all individuals who have or will have the responsibility of using, maintaining or servicing this product. The product will perform as designed only if it is used, maintained and serviced in accordance with the manufacturer's instructions. The user should understand how to set the correct parameters and interpret the obtained results.

WARNINGS !

- Never operate the monitor when the cover is removed.
- Remove the monitor cover only in an area known to be non-hazardous.
- Use only mPower's sensor and accessories. Substitution of components will impair suitability for intrinsic safety and void warranty.
- The instrument should be calibrated after installation before initial use and checked by exposing it to a known concentration calibration on a regular basis.
- Ensure that the gas inlet is not blocked.
- Make sure that all filters are clean and replaced on a regular basis.
- Remove the sensor only if necessary for repair. Zero and span calibration are required once the sensor is removed and re-inserted or replaced.

Special Conditions for Safe Use

The VOXI monitor must be calibrated if it does not pass a bump test, when a new sensor has been installed, or at least once every 180 days, depending on use and sensor exposure to poisons and contaminants.

1. General Information

The VOXI EC MP840 is a point-type toxic gas transmitter designed modularly with smart electrochemical sensor technology and an integral flameproof enclosure for fixed applications. The versatile platform offers more than 10 sensor options with auto-zeroing and offline calibration. Three-wire 4-20 mA analog and RS485 digital (for Modbus) signal outputs are standard. Three sets of programmable relays allow triggering of external alarms such as a siren or visual beacon. Various applications include oil & gas, petrochemical, chemical, metallurgical, pharmaceutical, semiconductor, environmental monitoring, and other industry facilities.

1.1 Key Features

- Selection of more than 10 chemical gas types
- Smart modules with sensor identification and manufacturing data
- Sensor diagnosis, temperature compensation and auto-zeroing
- LCD with backlight that changes color according to alarm condition
- Calibration due date notification
- 3 Wires for 4-20 mA and RS485 ModBus output
- Infrared remote programmer for settings, calibrations and adjustments
- Error codes for easy troubleshooting
- Recoverable factory settings
- Overrange protection, reverse polarity protection
- IP-67 rating
- IECEx certification

2. User Interface

The VOXI user interface consists of one large LCD Display showing the gas concentration, a power status LED, an alarm LEDs, and a fault indicator LED. Calibration is performed and operating parameters are entered using a handheld IR remote programmer.

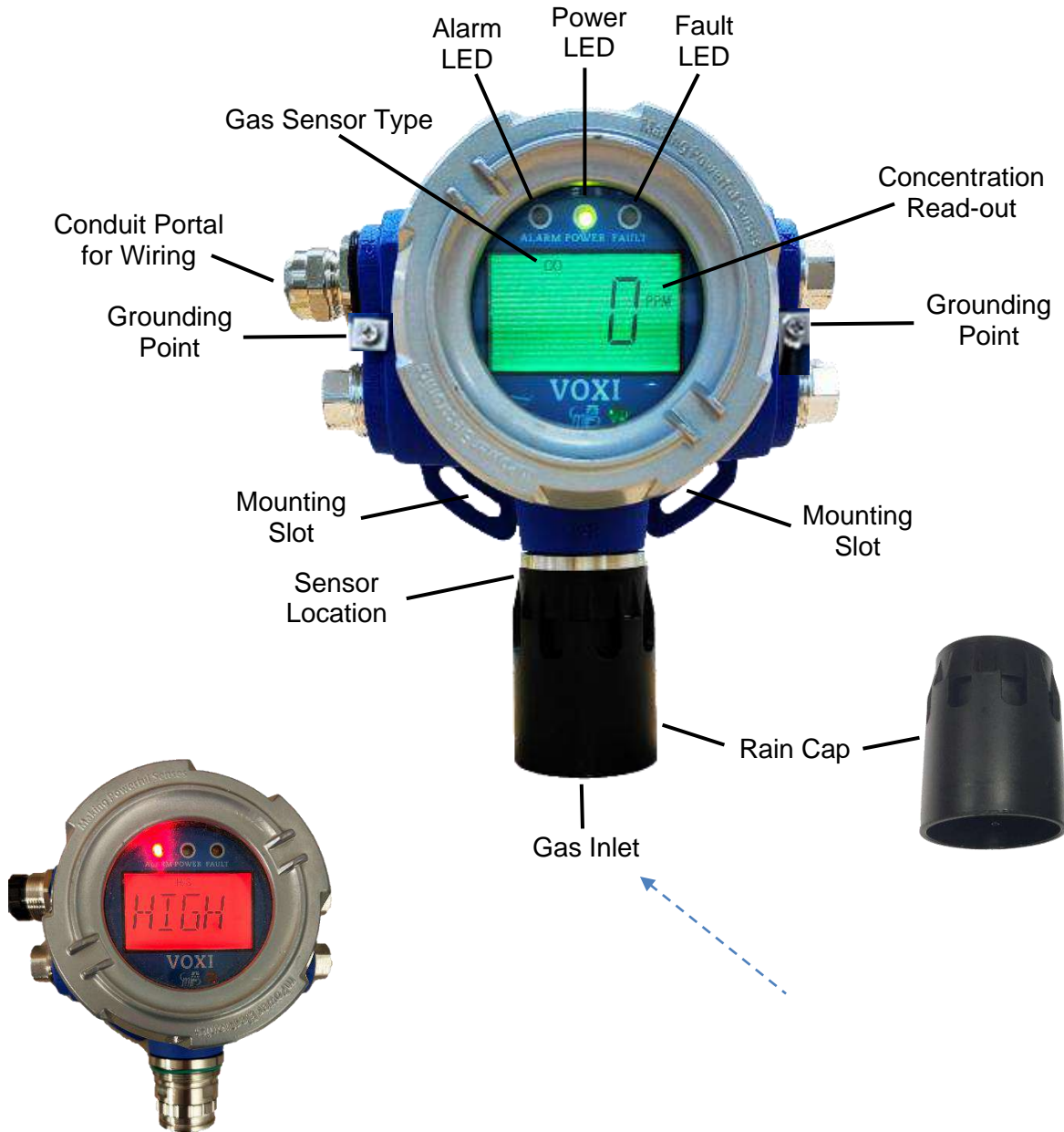

Backlight changes color to indicate alarms or faults

3. Installation

WARNINGS !

- The VOXI EC has CNEX and IECEx certifications for use in hazardous gas locations. Check for certification requirements before installing.
- The VOXI EC has NO HAZARDOUS GAS CERTIFICATION when used with 16/3SOOW cable for oil and water.
- Before installation, ensure that all power is disconnected.
- Before removing the monitor cover for service, disconnect the power supply and ensure that the area free of combustible gases and vapors.
- For European locations, installation must comply with EN-60079-14.
- The instrument should be calibrated after installation before initial use and checked by exposing it to a known concentration calibration gas on a regular basis.
- Remove the sensor only if necessary for repair. Zero and span calibration are required once the sensor is removed and re-inserted or replaced.

3.1 Mounting

3.1.1 Mounting Location

Because the VOXI EC samples by diffusion, it should be installed directly in the area to be measured.*¹ For an entire room to be monitored, there is a reliance on good air circulation within the room, since the VOXI can only measure in the immediate vicinity of its inlet. If the VOXI must be mounted remotely, the gas must be pumped to the inlet because it has no sampling pump of its own.

3.1.2 Mechanical Mounting Options

The VOXI EC is designed for wall mount or pole mount using the screw-holes provided, centered 5.25 inches or 134 mm apart. An optional mounting bracket (P/N M024-3003-000) is available that allows the unit to be offset about 1 cm from the wall or pole.

If mounted outdoors, ensure that the gas inlet is directed downwards and the raincap is installed to minimize the chance of precipitation entering the sensor inlet.

The shape and dimensions of VOXI are shown in the figure below:

*¹ Future VOXI EC versions that have certifications will be able to be installed and operated in hazardous-gas locations, but because the housing cannot be opened for service in the presence of flammable gases, the VOXI EC is easier to maintain if installed in a non-hazardous location or an area that can be vented to remove hazardous gases before opening the housing.

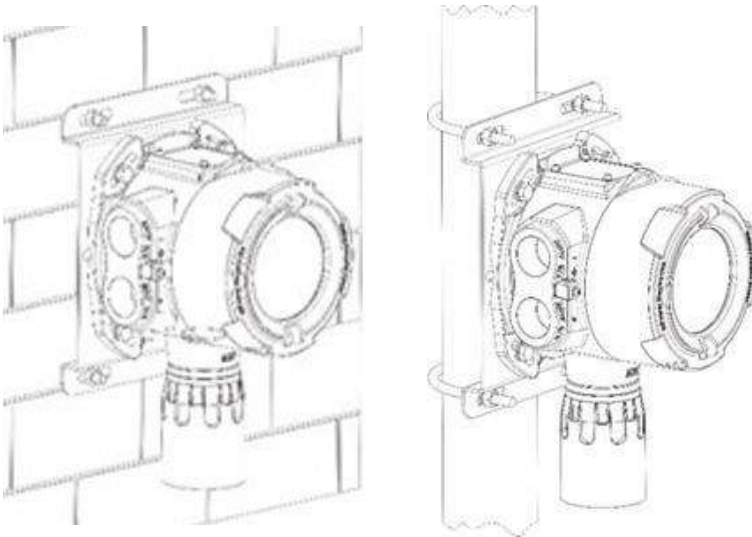
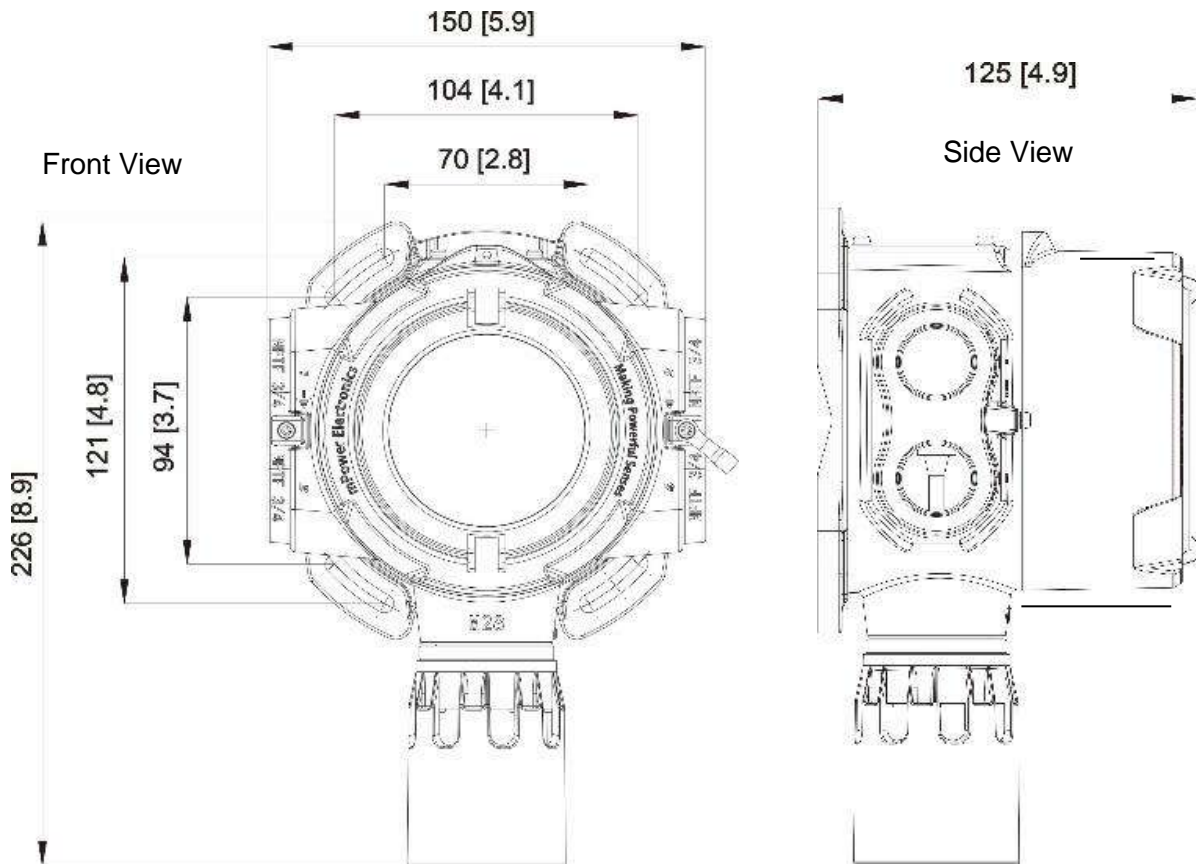

Wall Mount

Pole Mount

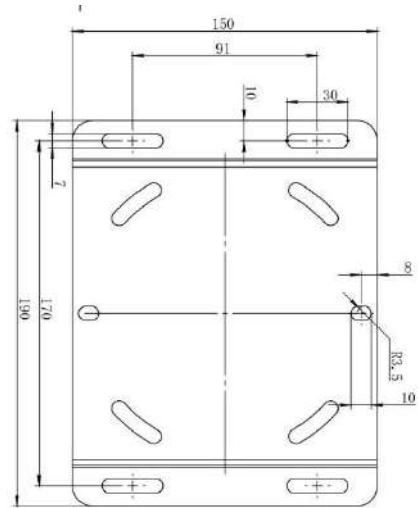

Bracket Dimensions (mm)

3.2 Rain Cap

If mounted outdoors, the rain cap should be installed to reduce the chance of precipitation ingress. If mounted indoors, the rain cap may be removed.



3.3 Electrical Connections

3.3.1 Internal Wiring

Four openings are provided in the explosion-proof housing, covered by hex-head plugs which can be removed to attach conduit for remote wiring, alarm beacon, antenna, and/or other wire connections. For internal connections, unscrew and remove the cover by first loosening the lock screw located on the side, using an Allen wrench. Pinch the buckles on both sides of the instrument assembly to release and then lift it out. Unplug the sensor plug from the PC board.



The schematic below shows the internal wiring connections. Insert the wire through the conduit hole and connect to the corresponding pin numbers of the three terminal blocks on the bottom of the assembly. These blocks accept 12AWG to 24AWG wire (0.2 to 4.0 mm²). Input power requirements are <5W, 12-30 VDC and should be connected between Terminals 14-GND and 15-V+.

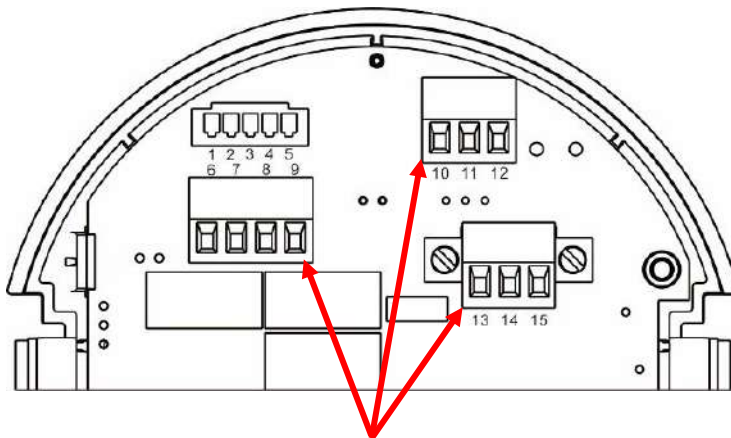

Terminal Blocks

1	2	3	4	5	6	7	8
ALARM HIGH	ALARM LOW	ALARM FAULT	NC	+V	ALARM HIGH	ALARM LOW	ALARM FAULT

9	10	11	12	13	14	15
COM	RS 485A	GND	RS 485B	4-20mA OUTPUT	GND	-V

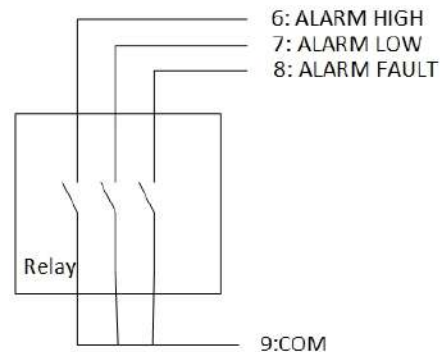

Alarm outputs on Terminals 6-9 are normally-open dry contacts that close on alarm. The 4-20 mA output should be connected to Terminals 13 and 14. RS485 should be connected to terminals

10 & 12, and terminal 11 is for the RS485 shielding line. The +V terminals 5 and 15 are equivalent and internally connected, as are GND terminals 11 and 14.

3.3.2 Grounding

The internal ground point is shown in the left figure below. An external ground wire (AWG11 recommend) should be connected to the VOXI housing (right figure below).



3.3.3 Maximum Wiring Length

The maximum signal transmission distance can be estimated from the resistance of the shielded cable, allowing for a maximum of 150 Ω , as shown below (actual maximum distance may vary).

Cross-sectional Area		Resistance (Ω /yd)		Maximum Distance (miles)
mm ²	AWG	Wire	Loop	
1.0	17	0.0165	0.0329	2.6
1.5	15	0.0110	0.0220	3.9
2.5	13	0.0067	0.0135	6.3

! WARNING !

The VOXI EC has NO HAZARDOUS GAS CERTIFICATION when used with 16/3SOOW cable for oil and water.

3.3.4 Baseline 4 mA Signal Adjustment

If sending the 4-20 mA signal to a remote controller, during the field installation the VOXI EC analog output should be adjusted. See VOXI EC Field Service section below for procedures.

3.3.5 MODBUS Message RTU

3.3.5.1 Modbus RTU Framing

The VOXI uses RTU framing for MODBUS messages. The following is an excerpt of the *MODBUS over Serial Line Specification and Implementation Guide v1.02 (Dec.2006)* with more information available at <http://www.modbus.org/> and <http://www.modbus.org/specs.php> :

A MODBUS message is placed by the transmitting device into a frame that has a known beginning and ending point. This allows devices that receive a new frame to begin at the start of the message, and to know when the message is completed. Partial messages must be detected and errors must be set as a result. In RTU mode, message frames are separated by a silent interval of at least 3.5 character times. In the following sections, this time interval is called t3.5.

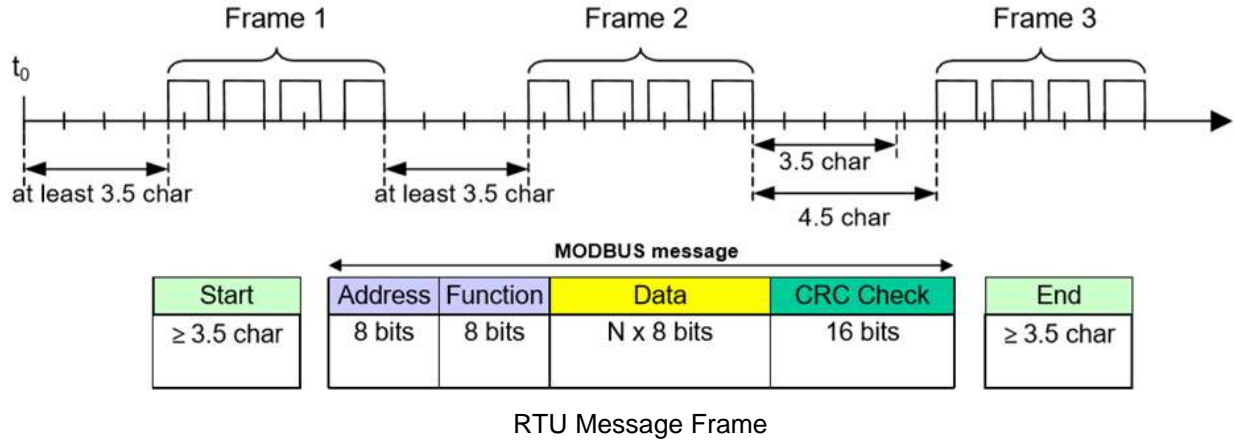

The entire message frame must be transmitted as a continuous stream of characters. If a silent interval of more than 1.5 character times occurs between two characters, the message frame is declared incomplete and should be discarded by the receiver.

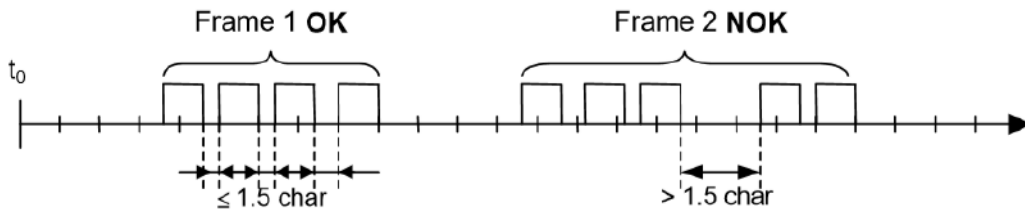

Remark: The implementation of RTU reception driver may imply the management of a lot of interruptions due to the t1.5 and t3.5 timers. With high communication baud rates, this leads to a heavy CPU load. Consequently, these two timers must be strictly respected when the baud rate is equal to or lower than 19200 Bps. For baud rates greater than 19200 Bps, fixed values for the 2 timers should be used: it is recommended to use a value of 750 μs for the inter-character time-out (t1.5) and a value of 1.750 ms for inter-frame delay (t3.5)

3.3.5.2 Modbus RTU Communication Settings

VOXI detectors support RS-485 communication, as a Modbus RTU.

Mode: RTU

Baud rate: 4800, 9600, 19200 (default 19200)

Start bits: 1

Data bits: 8, LSB first

Parity bit: none

Stop bits: 1

Detector ID: 1~247 (default 136)

3.3.5.3 Modbus RTU Functions

Detector supports function 0x03 (Read holding registers) only.

Request:

Device Address	Function Code	Register Address		Quantity of Registers		CRC	
		High Byte	Low Byte	High Byte	Low Byte	Low Byte	High Byte
Detector ID	3	Addr.H	Addr.L	Quantity.H	Quantity.L	CRC.L	CRC.H

Response:

Device Address	Function Code	Byte Count	Register Values	CRC	
Detector ID	3	N	N bytes data, Highest byte first	CRC.L	CRC.H

N = 2 x Quantity of Registers

3.3.5.4 Modbus RTU Register Address

Register address	Register name	Description
0x0000	Firmware version	Read-only, every 4 bits represent a hexadecimal number, such as 0x1ABC for version V1.10.11.12
0x0001	High part of firmware build date	Read-only, year is represented by hexadecimal digits, such as 0x07E1 for 2017
0x0002	Low part of firmware build date	Read-only. The high byte represents the month and the low byte represents the day. For example, 0x0C1E represents December 30
0x0003	MP8XX ID	Read-only, such as 0x0002
0x0006	MP8XX address	Read and write, used for MODBUS communication, valid value is 1-247. The default value is 0x88 (136 in decimal).
0x0007	MP8XX SN high byte	Read-only, 2 characters in ASCII
0x0008	MP8XX SN	Read-only
0x0009	MP8XX SN	Read-only
0x000A	MP8XX SN	Read-only
0x000B	MP8XX SN	Read-only
0x000C	MP8XX SN low byte	Read-only
0x0023	MP8XX gas concentration data high byte	Read-only, signed integer (bit16~bit31). For example, reading data = 0x12345678, this register returns 0x1234; Can read 2 registers data starts from address 0x0023 to get the whole reading data.
0x0024	MP8XX gas concentration data low byte	Read-only, signed integer (bit0~bit15). For example, reading data = 0x12345678, this register returns 0x5678
0x0025	Measurement unit and reading decimal point (DP)	Reading-only. High byte is Unit ID, low byte is decimal point (DP). For example, unit ID=2, DP=1, the register returns 0x0201. MP812/MP815 do not support register 0x0025, its Unit ID is always 2, DP is always 3. The display reading = data / (10 ^ DP), where data is the integer from register (0x0023 and 0x0024). For example, reading data = 0x12345678 (305419896 in decimal), unit ID = 2, DP=1, the display reading is 30541989.6 ppm.

Unit ID	Unit Name	Remark	Unit ID	Unit Name	Remark
0x01	10 ⁻⁶		0x06	μmol/mol	Same as ppm in value
0x02	ppm		0x07	ppb	1/1000 ppm
0x03	%	For Oxygen sensor	0x08	μg/m ³	
0x04	%LEL	For LEL sensor	0x09	%VOL	For LEL sensor
0x05	mg/m ³				

4. Operation

4.1 Standard Operation

Once installed and power is turned on, the VOXI EC cycles through a start-up sequence (below).

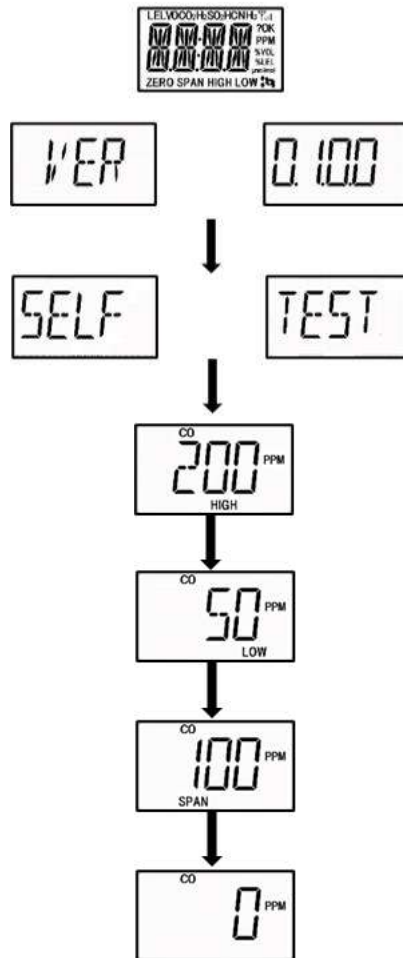

After start-up, the VOXI EC samples the gas by diffusion and runs continuously to measure the toxic gas (or oxygen), display the concentration readout and any alarms, and send any output and alarm signals to external devices. When an alarm level is exceeded, the Alarm LED flashes and the display backlight changes color.

4.2 Programming using Hand-held Remote

Configuring and calibrating the VOXI EC is done using a handheld remote programmer. There is no magnetic key or other means of programming the VOXI EC directly. Communication with the transmitter functions from up to 3 m (10 ft) distance when directed straight at the transmitter display instead of from an angle.



WARNING !

- VOXI EC monitoring is turned off during communication with external devices.
- Perform programming and calibrations only during times known to be free of toxic or combustible gases and vapors.

4.2.1 Battery Installation

The remote programmer uses a CR2025 3V battery or equivalent. To remove or replace the battery, place the unit face down, push the retaining hook inward and slide out the battery holder.



4.2.2 User Interface

Press the Main Menu Access button on the Remote Programmer to display the user interface on the VOXI LCD. Program operations can be selected using the cursor movement arrows. Short-cut operations can be conducted using the Zero and Span buttons to quickly perform routine zero and span calibrations. The firmware is factory-set and currently cannot be changed by the user.

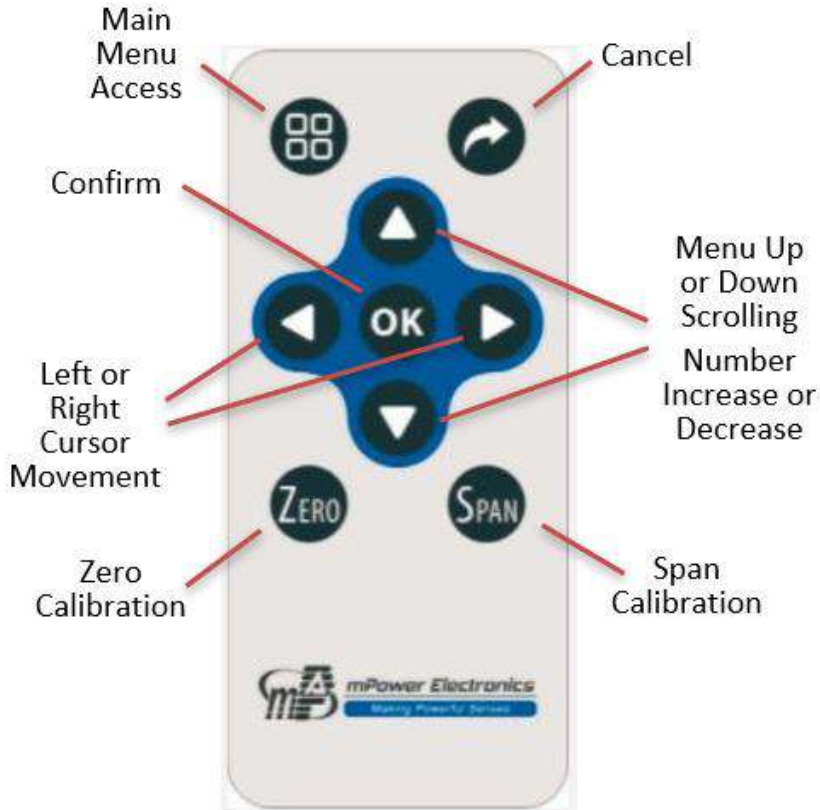

4.2.3 Navigating Menus and Sub-menus

Press the Main Menu Access button and use the Up and Down arrows to scroll through the menu. Use the Right and Left arrows to enter or exit a menu item. When entering numerical values, use the Left or Right arrows to move the cursor, and the Up and Down arrows to increase

or decrease the values, When the cursor is moved to the “?”, press OK to save or enter. To exit a sub-menu, press the cancel key . To exit the Main Menu, scroll down to the EXIT screen and press OK. The display will also automatically return to concentration readings after about a minute of non-use.

Enter the menu:

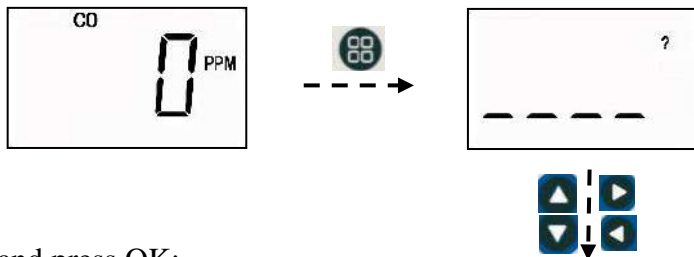

Enter the password and press OK:



Scroll through the menu:

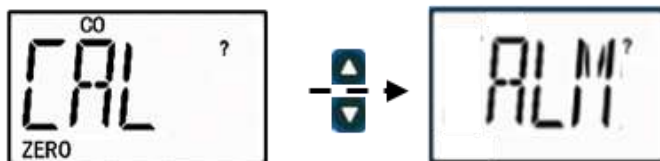

Exit the menu:

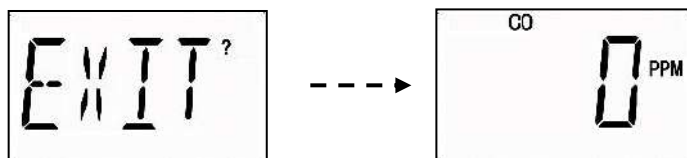

BASIC and ADVANCED Menus

There are two menus

- **Basic Menu** is accessed using default Password 0000. This allows basic field operations such as calibration, setting alarm levels, and communication with PC for firmware upgrades.
- **Advanced Menu** is accessed using default Password 8888. This allows access to additional advanced features such as changing passwords, changing concentration units, setting location ID, etc.

The Basic Menu and sub-menus are listed below

Display	Main Menu	Sub-Menu 1	Sub-Menu 2	Sub-Menu 3
CAL	Calibration	Zero Calib	Span Calib	Set Span Value
ALM	Set Alarm Limits	Low Alarm	High Alarm	
COMM	Communicate to PC (Factory & Service use only)			
EXIT	Exit			

The table below lists all Advanced Menus and their sub-menus.

Display	Main Menu	Sub-Menu 1	Sub-Menu 2	Sub-Menu 3
CAL	Calibration	Zero Calib	Span Calib	Set Span Value
ALM	Set Alarm Limits	Low Alarm	High Alarm	
CF	Set Correction Factor			
PSWD	Set Password	Basic Password	Adv. Password	
UNIT	Set Concentration Unit			
BPS	Set Baud Rate			
4_20	4-20 mA Adjust	4 mA Adjustment	20 mA Adjustment	
SITE	Set Site ID			
RST	Reset to Default Values			
COMM	Communicate to PC (Factory & Service use only)			
EXIT	Exit Programming			

The Advanced Main Menu path is shown below

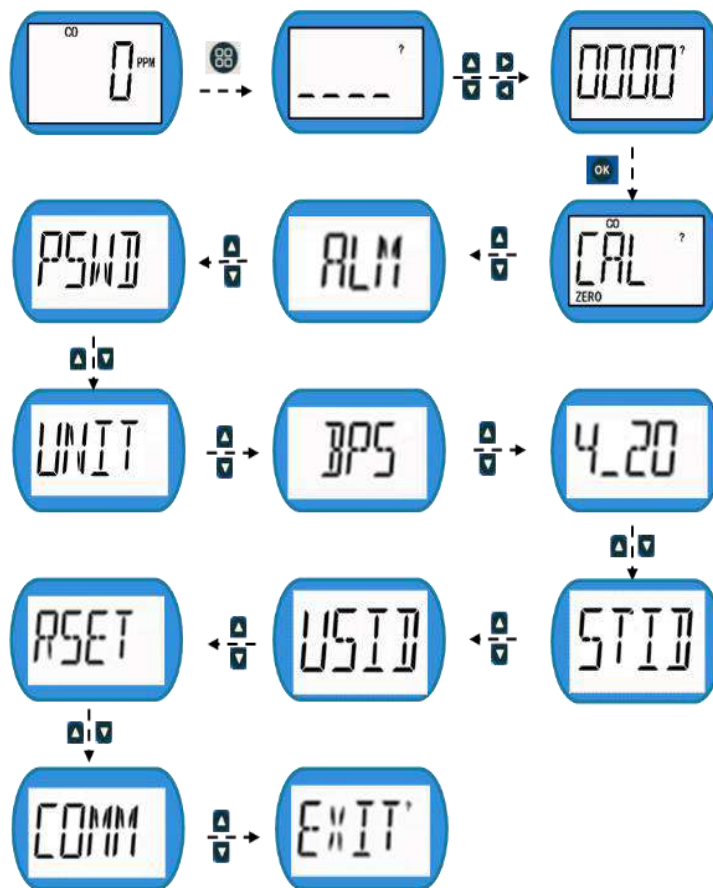

Calibration (CAL)

Perform zero and span calibrations. See the following Calibration Section for details.

Alarm (ALM)

Set the numerical values for the low and high alarm limits.

Correction Factor (CF)

A correction factor can be used when the calibration gas is different from the measured gas.

Password (PSWD)

Change the passwords for either Basic or Advanced configurations.

Unit (UNIT)

Gas concentration units can be set to **ppm** (parts per million) or **µmol/mol** (micromole per mole). For **oxygen** the only unit is % by volume.

Baud Rate (BPS)

The Baud Rate options are 4800, 9600 and 19200 bps and should be set to match that used in the MODBUS messaging protocol.

Analog Output (4_20)

If sending the 4-20 mA signal to a remote controller, during the field installation the VOXI analog output baseline should be adjusted. Read the current on terminal 13 using an ammeter while adjusting the raw counts. The default values are 530 counts for 4 mA (0 ppm) and 2600 counts for 20 mA. No gas needs to be applied during these operations.

Site ID (SITE)

Label the station or location.

Reset (RST)

Reset all parameters to their default values.

Communication (COMM)

Communication to PC for firmware upgrade, sensor firmware change, Modbus setting, etc. This feature requires special software currently available only to authorized service centers.

4.2.4 Default Settings

Sensor	Span Value [‡]	Low Alarm [‡]	High Alarm [‡]
O ₂	0 % Vol O ₂ (100% N ₂)	19.5 % Vol	23.5 % Vol
CO	1000 ppm	35 ppm	50 ppm
H ₂ S	25 ppm	10 ppm	20 ppm
SO ₂	5 ppm	5 ppm	10 ppm
HCN	10 ppm	5 ppm	10 ppm
NH ₃	100 ppm	25 ppm	50 ppm
Cl ₂ *	10 ppm	0.5 ppm	1 ppm
NO*	25 ppm	10 ppm	20 ppm
NO ₂ *	5 ppm	3 ppm	5 ppm
PH ₃ *	5 ppm	1 ppm	4 ppm
ETO*	20 ppm	10 ppm	20 ppm

[‡]Default settings subject to change – always check instrument. *Check sensor availability.

4.3 Calibration

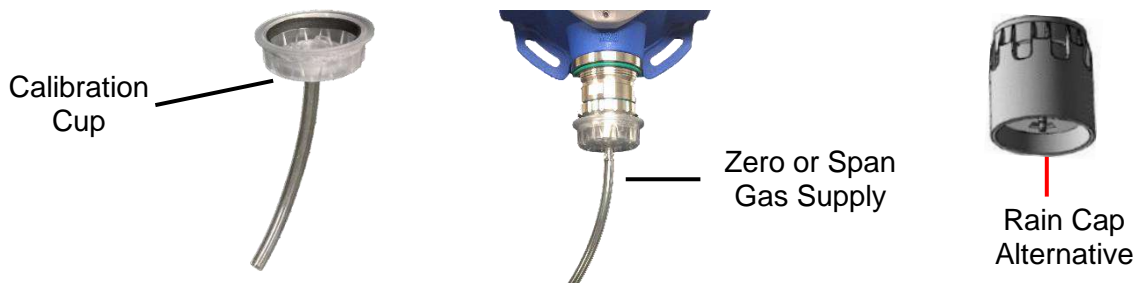

1. Before calibration, it is good practice to examine the inlet filter and replace as needed.
2. **Zero Calibration:** Scroll to the **CAL ZERO** menu. Alternatively, press the short-cut “Zero” button on the programmer. Supply clean air to the inlet. If the VOXI EC is mounted in an area where ambient air contains detectable concentrations of gases, attach the calibration cup and supply clean gas (air) directly from a cylinder fitted with a fixed-flow regulator of about 0.3-0.6 LPM. If no calibration cap is available, the rain cap may be used. Connect the zero gas directly to the rain cap.
3. For **Oxygen sensors**, the zero gas is ambient air (20.9% O₂) and 0% O₂ is set using pure N₂ during span calibration (see below)
4. Click ‘OK’ to initiate the 30-second count-down timer, after which Pass or Fail is displayed. Click ‘OK’ to move to Span or continue to Exit.
5. To abort, press  during the count-down.

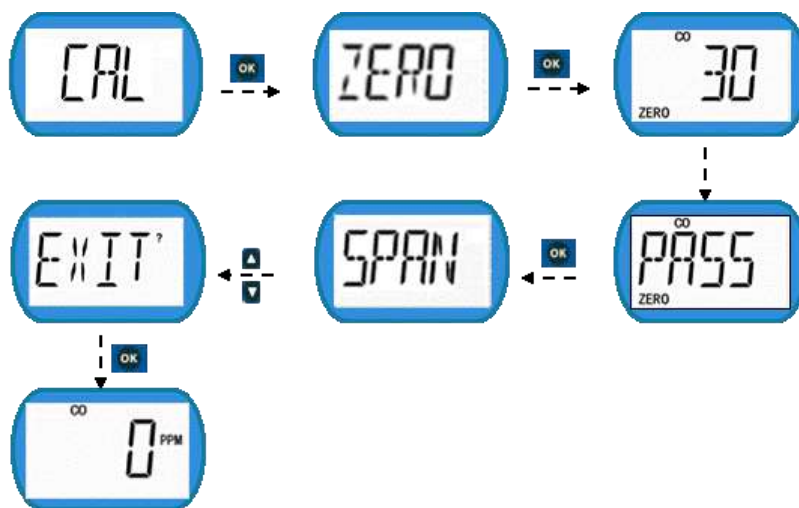

Or, using the short-cut Zero button on the remote programmer:

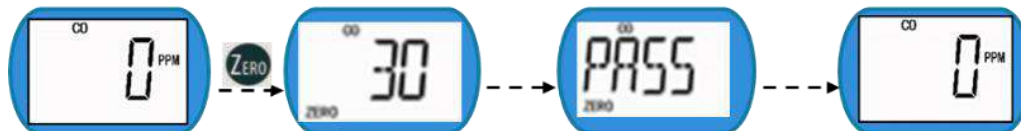

6. **Span Calibration:** Scroll to the **CAL SET** menu and ensure that the Span Gas setting matches the concentration of the gas in the calibration cylinder.

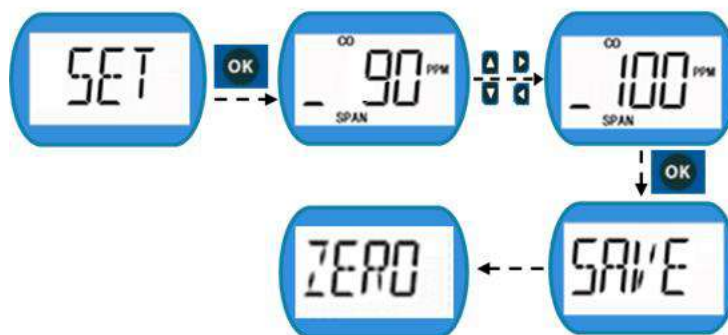

7. For **Oxygen sensors**, set the span value to 0% O₂ to calibrate with pure N₂. This N₂ span must be done at least once upon installation. The default span setting is 18% O₂, but this reading (or any other value except 0% O₂) is not used for calibration, only as calibration check to ensure it reads within typical error limits. The 0% O₂ calibration need not be done frequently because it typically does not change significantly for the life of the sensor, and small changes do not affect readings in the breathing are range near 20.9%. Thus, an 18% O₂ calibration check after a 20.9% air zeroing is usually adequate, unless working in inert gases near 0% O₂.
8. Scroll to the **CAL SPAN** sub-menu. Alternatively, press the short-cut “Span” button on the programmer. Attach the calibration cup and supply span gas directly from a gas cylinder fitted with a fixed-flow regulator of about 0.3-0.6 LPM to the inlet. Click ‘OK’ to initiate the count-down timer, after which Pass or Fail is displayed. The count-down time depends on the type of sensor and ranges from about 45 to 180 seconds.
9. To abort, press  during the count-down.
10. Use of fixed-flow regulators below 0.3 LPM or above about 0.6 LPM will cause poor calibration. A regulator with flow higher than 0.6 LPM can be used if an open T fitting is placed in line between the regulator and VOXI EC inlet to allow excess gas flow to escape without being forced through the instrument.
11. The **Calibration Interval** should be at least every 6 months. However, the interval must be defined by the user and may be shorter because it depends on the application and local conditions. We recommend starting with weekly bump tests to check the response of the sensor and need for filter changes, and then increasing the length of time between checks and calibrations as experience is gained in the application. In all cases calibration should be performed at least every 180 days. See mPower TA Note 3 for more details.

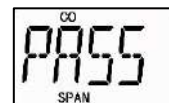

5. Maintenance

The VOXI EC requires regular filter replacement and possibly sensor replacement if used in areas of high dust or condensation. Sensor life is typically 1-3 years depending on sensor type.

5.1 Filter Replacement

If the inlet filter is dirty or clogged, discard it and replace it with a new filter. Dirty filters can be recognized by symptoms such as:

- Visible filter discoloration
- Visible moisture accumulation
- Weak sensor response

We recommend filter replacement every month, and more frequently, possibly weekly, when used under very dusty or wet conditions.

Remove the rain cap (if used) and unscrew the metal sensor housing. Remove the mesh screen and filter, replace the old filter with a clean one, and reassemble the mesh and sensor housing.

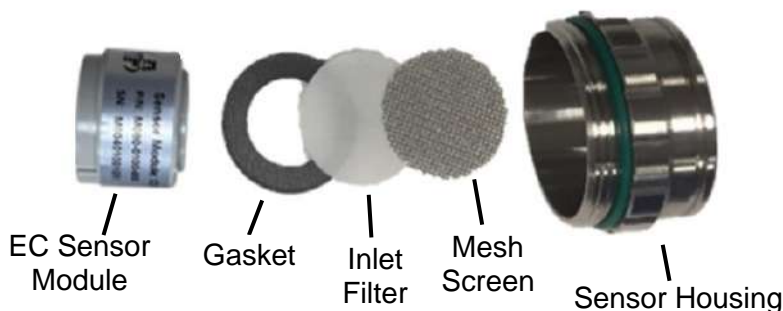

IMPORTANT! The VOXI EC should not be operated without a filter. Operation without a filter may damage the instrument and shorten the life of the sensor.

5.2 Sensor Replacement

⚠ WARNING!

Replace sensor only in non-hazardous environments.

Remove the rain cap, metal sensor housing, and other components as described above for filter replacement. Grasp the grey sensor module and carefully pull out to remove the sensor. Insert a new sensor module, and reassemble in reverse order.

IMPORTANT! Always perform a full calibration after removing a sensor.

5.3 LCD or Circuit Board Replacement

The entire LCD/Circuit board assembly must be replaced as a unit as they cannot be separated, as follows:

1. Open the housing and remove the cover and circuit board/LCD assembly as described in Section 3 for wiring. Disconnect the wiring plugs
2. Replace the Circuit Board/LCD assembly and re-assemble in reverse order.



6. Troubleshooting

Problem	Possible Reasons & Solutions
Error Code E001	Reason: Firmware does not support model type Solution: Install correct firmware
Error Code E002	Reason: Sensor Error Solution: Check or replace sensor
Error Code E003	Reason: Different (supported) sensor type installed Solution: Install original type sensor. Or if type change is desired, restart power and confirm sensor type change upon queries SEN CHG? and SURE?
Error Code E004	Reason: Sensor unsupported or not match factory setting Solution: Replace sensor with a supported type or upgrade to firmware that supports the sensor
Error Code E005	Reason: Calibration data invalid and no default factory calibration data Solution: Calibrate properly or return unit for factory calibration
Readings abnormally High	Reasons: Dirty filter(s). Dirty sensor module. Excessive moisture or water condensation. Incorrect calibration. Cross-sensitive gases present. Solutions: Replace filter(s). Clean or replace sensor module. Calibrate the unit. Install in area without cross-sensitive gases.
Readings abnormally Low	Reasons: Dirty filter(s). Weak or dirty sensor. Incorrect calibration. Solutions: Replace filter(s). Replace sensor module. Calibrate the unit.
Lost password	Solutions: Call Technical Support at (408) 320-1266

For replacement parts please contact an authorized mPower Service Center.

6.1 4-20 mA Alarm Signals

To aid in troubleshooting, in addition to display text and LEDs, the 4-20 mA output identifies some alarms, as follows:

4-20 mA Signal	Condition
0 mA	Off or booting up during the start-up sequence.
1 mA	Warm up mode (for certain sensors like IR or some reactive toxic gases)
2mA	Any "FAULT" condition that may cause a bad output from the sensor, or potential threat to impact sensor output, including: <ol style="list-style-type: none"> 1) Hardware failures: including pump, sensor, any other hardware failures. Low input voltage, main power lost (if with backup battery), sensor NEG, sensor removed, etc. 2) CAL failure
3mA	Transmitter is in menu, including in "Cal" mode during Zero or Span Cal
4~20mA	4mA: Sensor reading 0 20mA: Sensor reading full scale
22mA	Over-Range Fault when reading is 10% over full scale.

NOTE: If a Cal Failure has been corrected with a good calibration after the cause is corrected, everything should proceed normally. If parts are replaced while the transmitter is off, it should still be in Cal Failure until a good calibration is performed after restart. Exception: If the sensor is replaced and the calibration data are stored on the sensor microprocessor, then it will likely reboot with no fault. However, it will still be preferable to perform a good calibration for the local ambient atmosphere and conditions.

7. Technical Specifications

Detector Specifications

Size	8.9 x 5.9 x 4.9 in (226 x 150 x 125 mm)
Weight	5.7 lbs. (2.6 kg)
Sensors	Electrochemical sensor modules
Calibration	Two-point calibration (zero & span)
Response Time	30 to 120s (t_{90} varies with sensor type)
Temperature	-40° to +131°F (-40° to +55°C) -40° to +158°F (-40° to +70°C) intermittent
Humidity	10% to 95% Relative Humidity (non-condensing)
Pressure	86 to 106 kPa (0.85 to 1.05 atm)
Power	<1W; 10-30 VDC supply
Sampling	Diffusion
Display	4-digit segmented LCD
Configuration	Via remote infrared programmer
Outputs	Analog: 4-20 mA (3 wires) Digital: RS-485 ModBus 3 Relays Wireless ISM 915MHz (optional) 1 mile line of sight
Alarms	LCD & LED flashing, external strobe and horn (optional)
Housing	Explosion-proof aluminum alloy
Housing Entries	4 Conduit entries 3/4" NPT 1 Port M28x1 fitting
Installation	Pipe bolt or wall mount
IP Rating	IP-67
EMI/RFI	Compliant with EMC Directive 2014/30/EU
Safety Certifications	IECEX Ex db ia IIC T6 Gb Ex ia tb IIIC T80°C Db CNEX Ex d IIC T6
Installation	Pipe holding, wall mount
Warranty	2 Years on CO & H ₂ S sensors, 1 year on others

Standard

- Gas Transmitter with Sensor installed
- Rain Shield & Calibration Cap
- Infrared Remote Programmer
- Quick Start Guide
- Calibration Certificate

Optional

- Mounting Bracket
- Strobe and Horn with 3/4" NPT Fitting

Sensor Options

Sensor	Range	Resolution
O ₂ (Oxygen) Lead Free	0-30%Vol	0.1%Vol
CO (Carbon Monoxide)	0-500 ppm	1 ppm
	0-1000 ppm	1 ppm
	0-2000 ppm	1 ppm
H ₂ S (Hydrogen Sulfide)	0-200 ppm	0.1 ppm
	0-1000 ppm	1 ppm
SO ₂ (Sulfur Dioxide)	0-20 ppm	0.1 ppm
H ₂ (Hydrogen)	0-1000 ppm	1 ppm
HCN (Hydrogen Cyanide)	0-100 ppm	0.1 ppm
NH ₃ (Ammonia)	0-100 ppm	1 ppm
	0-1000 ppm	1 ppm
CO (H ₂ -resistant) *	0-1000 ppm	1 ppm
NO (Nitric Oxide) *	0-250 ppm	1 ppm
NO ₂ (Nitrogen Dioxide) *	0-20 ppm	0.1 ppm
Cl ₂ (Chlorine) *	0-50 ppm	0.1 ppm
PH ₃ (Phosphine) *	0-20 ppm	0.01 ppm
	0-1000 ppm	1 ppm
ETO (Ethylene Oxide) *	0-100 ppm	1 ppm

* Check availability

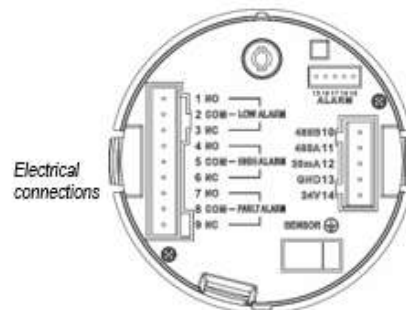
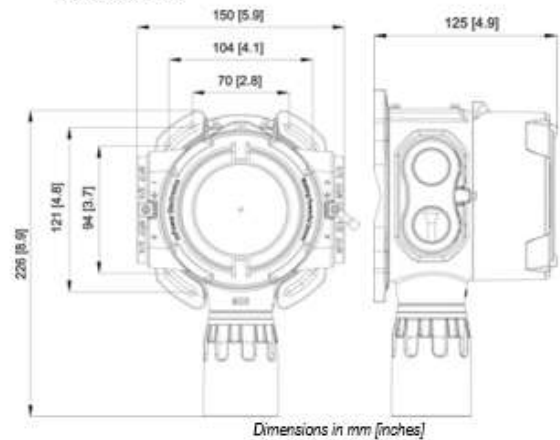

All specifications are subject to change without notice. Please check for updates at www.mpowerinc.com.

8. Replacement Parts

Description	Part Number	List Price*
IR Bluetooth Remote Programmer MP220 for VOXI EC/LEL	M024-0901-000	\$60.00
Mounting Kit for VOXI EC/LEL	M024-3003-000	\$60.00
Rain/Mud/Splash Cap for VOXI EC/LEL	M024-3006-000	\$15.00
Calibration Cap for VOXI EC/LEL	M024-3005-000	\$10.00
Inlet Filters for VOXI EC (pack of 10)	M024-2017-010	\$20.00
Metal mesh screens for VOXI EC (pack of 10)	M024-2016-010	\$35.00
Rubber sensor gaskets for VOXI EC (pack of 10)	M024-2018-010	\$10.00
Sensor housing cap for VOXI EC (with O-Ring)	M024-3007-000-SRP	\$30.00
Enclosure , explosion-proof, for VOXI EC/LEL incl. housing bottom, top & O-ring	M024-3008-000	\$200.00
Enclosure connector, 3/4" NPT for VOXI EC/LEL	M490-0146-000	\$20.00
Safety Barrier, for VOXI EC, with EC sensor cable	M024-3001-000-SRP	\$120.00
Replacement circuit board/LCD Assembly for VOXI LEL	M026-3001-000	\$250.00
Replacement circuit board/LCD Assembly for VOXI EC	M024-3002-000	\$250.00
Power Supply, 120-240VAC to 24-VDC, 1 W, with US wall plug	M500-0039-000	\$35.00

* Prices subject to change. Check the latest Price Guide for current pricing.

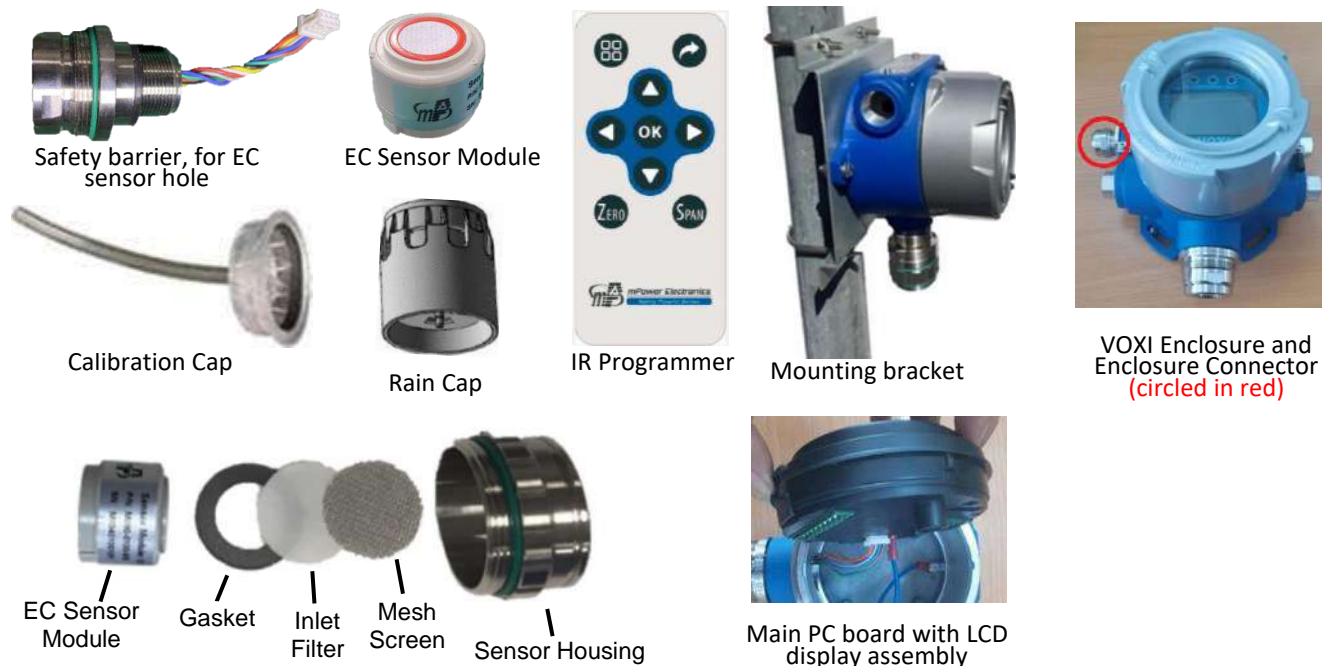

Technical Support and mPower Contacts

mPower Electronics Inc.

2910 Scott Blvd. Santa Clara, CA 95054

Phone: (408) 320-1266

Fax: (669) 342-7077

info@mpowerinc.com

www.mpowerinc.com

