FOTRIC

Handheld Thermal Imaging Camera

User Manual

About this manual

This manual is intended to be used as a guide. The photographs, graphics, icons and illustrations provided in this manual are for explanation and illustration purposes only and may differ from the specific product. Due to product version upgrade or other needs, FOTRIC may update this manual without prior notice.

Trademarks and images used in this manual are for illustrative purposes only and are copyrighted by the trademark owner.

Disclaimer

The products (hardware, software, etc.) provided in this manual may contain defects, errors, or failures, and FOTRIC makes no warranties of any kind, either express or implied, including, but not limited to, warranties of merchantability, satisfaction of quality, fitness for a particular purpose, non-infringement of third-party rights, etc. FOTRIC shall not be liable for any special, incidental, occasional, or consequential damages arising out of or in connection with the use of this manual or the products provided herein, including, but not limited to, loss of business profits, loss of use, or loss of use, or any other loss or damage to any third party. This includes, but is not limited to, damages arising from loss of business profits, loss of data or documentation.

To the fullest extent permitted by law, our liability will not exceed the amount you paid for the product.

After the product is connected to the Internet, it may face risks including but not limited to network attacks, hacker attacks, virus infections, etc. The Company shall not be responsible for any abnormal operation of the product or leakage of information caused by the product, but will provide you with technical support in a timely manner.

The product can sense motion detection and fire events under correct installation and configuration, but cannot avoid the occurrence of accidents or the resulting personal injury or property damage.

Thermal imaging products are classified by the U. S. Department of Commerce as an export controlled product under Export Control Classification Number (ECCN) 6A003. b. 4. b. This product contains a focal plane array under Export Control Classification Number (ECCN) 61002. a. 3. f. This product is not to be used in a controlled country (e. g., North Korea, Iran, Syria, Cuba, Sudan, etc.) Do not bring the product into, or use it in, a controlled country. Any loss or liability arising from the above behavior will be borne by you.

When using this product, please follow the applicable laws strictly. You agree that this

product is for civilian use only and may not be used in violation of third party rights, medical/safety equipment or other applications where product failure could result in life-threatening or personal injury, and in mass destruction fog, biological or chemical weapons, nuclear explosions, or any unsafe use of nuclear energy, or in applications that are dangerous or contrary to humanitarianism. Any loss or liability arising from the above applications will be at your own risk.

In the event of any conflict between the above and applicable laws, the provisions of the law shall prevail.

Preface



User Manual



Analysis Software



Symbols

 Warning	 Caution	 Note
Alerts the user to potential death or serious injury hazards.	Alerts the user to potential injury or property damage hazards.	Explanatory text that supplements and explains the body of the text.

Safety Information

The purpose of this content is to ensure that the user uses this product properly to avoid danger or property damage. Before using this product, please read this instruction manual carefully and keep it in a safe place for future reference.

Warning:

- Do not disassemble or modify the thermal imaging camera battery. The battery is equipped with safety and protective devices which, if tampered with, may cause the battery to overheat and may also result in explosion or combustion. If the battery is leaking and the leak gets in your eyes do not rub it, wash it with water and get immediate medical attention.
- Thermal imaging cameras using laser pointers. Do not view the laser beam directly with the human eye. The laser beam can cause eye irritation.
- If the unit is not working properly, contact your dealer or our company and do not disassemble or modify the unit in any way (unauthorized modifications or repairs cause problems at your own risk).

Caution:

- Avoid using the product in humid, dusty, extremely hot or cold environments, see the product's parameter table for specific temperature and humidity requirements.
- Do not touch the sensor or lens directly to avoid staining and damage from oil and various chemicals. If cleaning is necessary, slightly moisten a clean cloth and gently wipe off the dust. Close the lens cap when the camera is not in use.
- When the camera is turned on, it may take approximately 5-10 minutes for the camera to warm up before taking accurate readings.
- Avoid pointing the camera at the sun, strong energy sources (e. g. laser radiation equipment), or objects with extremely high temperatures, as this can cause burns and black spots that can lead to permanent and irreversible damage to the sensor.
- Avoid over-range use of the device, as this can cause burns and black spots that can lead to permanent and irreversible damage to the sensor.
- It is strongly recommended to use the original power adapter, the specific requirements of the power adapter see the product parameter table.
- To prevent the potential danger of data loss, always make a copy (backup) of the data on a computer.
- When storing the camera, it is strongly recommended to use the original box and place it in a cool, dry, ventilated environment free from strong electromagnetic fields.
- When shipping the camera, it is strongly recommended that it be shipped protected in its factory packaging.

Table of Contents

- PREFACE 1**
- TABLE OF CONTENTS 3**
- PRODUCT OVERVIEW 6**
 - 1. FRONT VIEW 6
 - 2. REAR VIEW 7
 - 3. SIDE VIEW 8
- 1. PREPARATION 10**
 - 1. CHARGING 10
 - 2. TURNING ON AND OFF 12
 - 3. SLEEP MODE 13
 - 4. FOCUSING 13
 - 5. STORAGE 13
- 2. THERMAL IMAGE DISPLAY 13**
 - 1. DROPDOWN MENU 13
 - 2. IMAGE MODE 14
 - 2.1. INFRARED IMAGE MODE 14
 - 2.2. T-DEF® BLEND MODE 15
 - 2.3. PICTURE-IN-PICTURE 15
 - 2.4. VISIBLE LIGHT IMAGE 15
 - 3. PALETTE 16
 - 4. COLOR ALARM 16
 - 6. DIGITAL ZOOM 18
 - 7. IMAGE OVERLAY INFORMATION 18
 - 7.1. GLOBAL INFORMATION DISPLAY 19
 - 7.2. OTHER ADDITIONAL INFORMATION DISPLAY 19
 - 8. MAXIMUM AND MINIMUM TEMPERATURE TRACKING 19

8.1.	GLOBAL MAXIMUM AND MINIMUM TEMPERATURE TRACKING.....	19
8.2.	REGIONAL MAXIMUM AND MINIMUM TEMPERATURE TRACKING.....	20
9.	HIGH TEMPERATURE DIFFERENCE EQUALIZATION IMAGING (T-TWB®).....	20
3.	MEASUREMENT AND ANALYSIS	20
1.	TEMPERATURE MEASUREMENT RANGE.....	20
2.	GLOBAL TEMPERATURE MEASUREMENT PARAMETERS.....	21
3.	MEASUREMENT TOOLS(ROI)	21
3.1.	ADD SPOTS	22
3.2.	ADD RECTANGLE	22
3.3.	ADD LINE.....	22
4.	REGIONAL EMISSIVITY CORRECTION (PARTIAL EMISSIVITY).....	22
5.	ANALYZING SOFTWARE	23
4.	BASIC PARAMETERS.....	23
1.	FOCUSING.....	23
1. 1.	MANUAL FOCUS	23
5.	CAPTURE FUNCTIONS	23
1.	SINGLE FRAME CAPTURE	23
1.1.	FILE NAMING FORMAT	23
2.	GALLERY.....	25
6.	DATA CONNECTION.....	26
1.	USB INTERFACE	26
7.	AUXILIARY FUNCTIONS	26
1.	LASER	26
2.	LED LAMP.....	27
3.	LANGUAGES	27
4.	SOFTWARE AND FIRMWARE UPGRADE.....	27
5.	DEVICE SET	28

EMISSIVITY TABLE 35

Product Overview

1. Front View

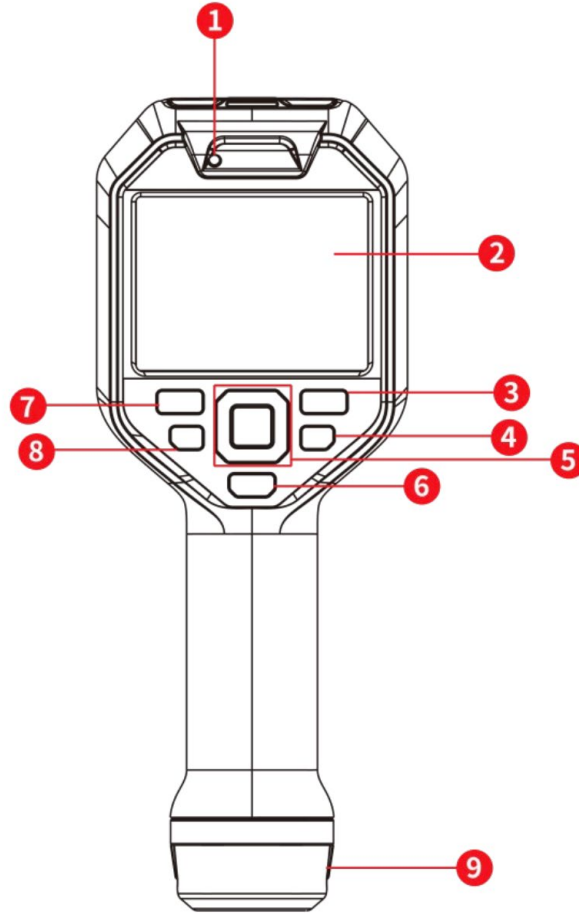

2. Rear View

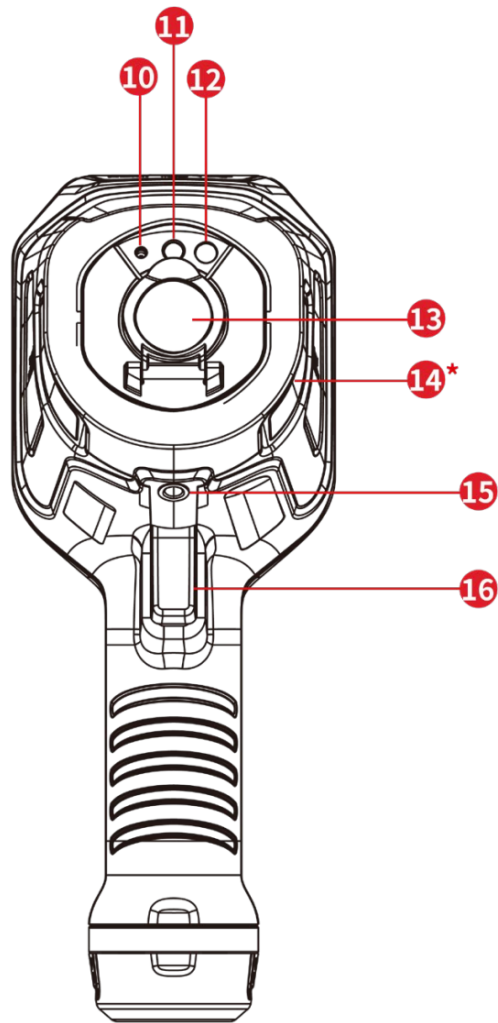

3. Side View

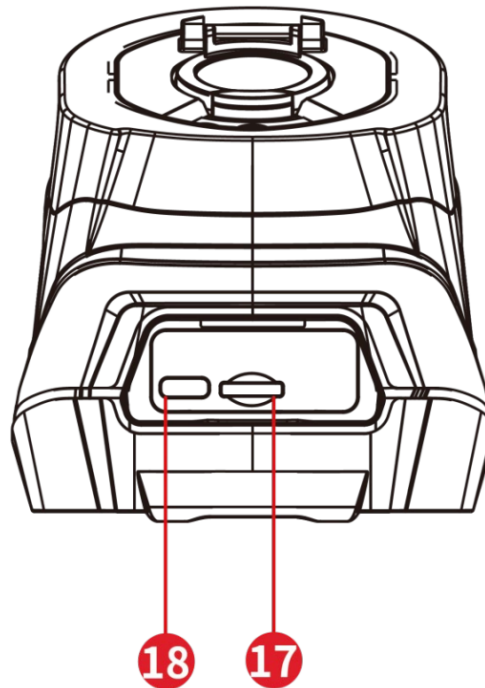

Appearance of the unit may vary with different models. Please refer to the actual product.

Components and Interfaces

	Name	Function
1	Status LED	<ul style="list-style-type: none">● Flashing green: charging● Green constant light: fully charged
2	Touch screen	<ul style="list-style-type: none">● Instant interface display● Touch screen operation
3	Gallery button	<ul style="list-style-type: none">● Short press: Enter gallery
4	Back button	Exit the menu or return to the previous menu

5	Navigation buttons	Menu Mode
		Non-Menu Mode
6	Shutter button	<ul style="list-style-type: none"> ● Short press: hit the stopper for temperature calibration (under the main interface)
7	Power button	<ul style="list-style-type: none"> ● Long press: start up, shut down the device ● Short press: rest screen, wake up device
8	Laser button	<ul style="list-style-type: none"> ● Press and hold laser on ● Release to turn off the laser
9	Battery	Lithium battery to provide power for the device
10	Laser	For laser indication
13	Digital camera	Visible light cameras
11	LED lamp	<ul style="list-style-type: none"> ● Flashlight: used as a flash when taking pictures ● Flashlight, used to add ambient light in dark environments
13	Infrared lens	Infrared imaging
14	Manual focus ring	Adjust the lens focus to make the image clear (focus-free products do not have this function)
15	Tripod threaded hole	Mounting tripod

16	Capture button	Freeze and Photo Buttons
17	TF card slot	For securing SD card
18	USB connection interface	<ul style="list-style-type: none"> ● For connecting USB Type-C cable for data transmission. ● Non-explosion-proof products support USB direct charging

1. Preparation

1. Charging

When using the thermal imager for the first time or when the power is low, please charge the thermal imager.

1.1. Charging through the charging dock

For quick charging take out the battery and mount it on the charging dock.

The voltage of the charging dock is 5VDC, please use the USB-C cable and the adaptor that came with the device.

Operation Steps

1. Put the battery into the charging base.
2. Connect the charging base to the power supply. If the charging base is working properly, one indicator light shows green.
3. The other indicator shows the charging status of the battery:
 - Red light is always on: charging is in progress.
 - Green light is always on: charging is complete.
4. When the battery is fully charged, disconnect the battery from the charging base. Disconnect the charging base from the power supply.

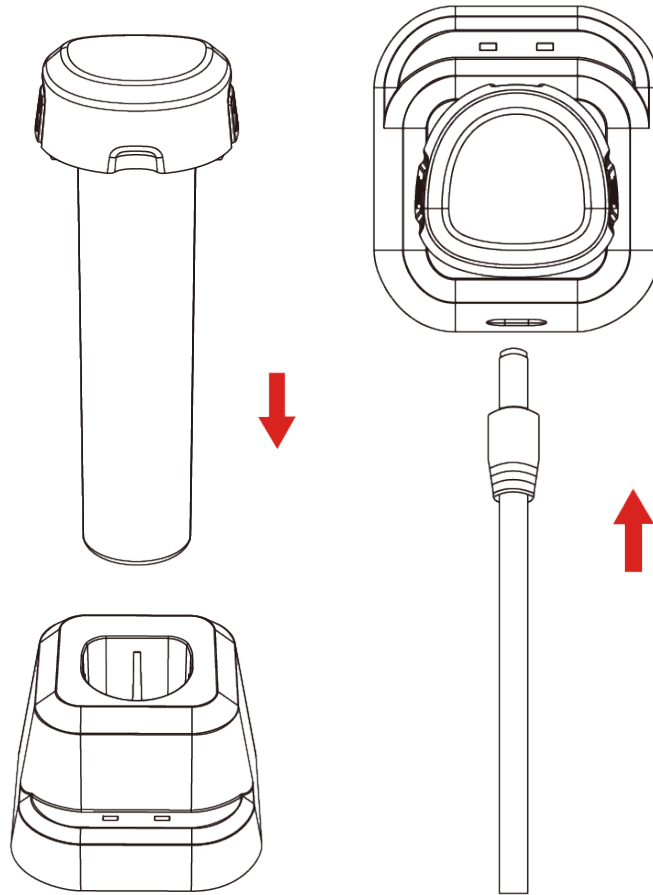

1.2. Direct charging via DC 5V

For convenient charging, the camera can be charged directly via the DC 5V power adapter.

Procedure

1. Place the battery in the battery compartment of the device.
2. Open the interface cover.
3. Connect the power supply and start charging the battery.

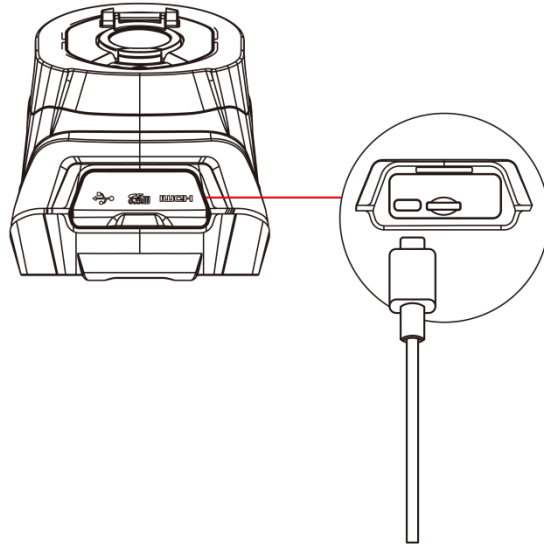

Note

Install the battery in the thermal imaging camera **and** charge it via the power adapter.

Open the **power** interface card cover **and** connect to the DC 5V power adapter for charging.

2. Turning On and Off

2.1. Turning on the camera

When the device is fully charged, turn on the device by **long pressing** the power on/off button. After the power on is completed, enter the real-time observation interface.



Note

When the device battery is low, please charge or replace the battery in time to avoid affecting the use.

2.2. Turning off the camera

The device can be turned off manually or by setting an automatic shutdown time.

Manual power off

Long press the on/off button to turn off the device.

Auto Power Off

Set the auto power off time. No touch screen, no button operation, no access to USB cable, the device will turn off automatically after the set auto shutdown time is met.

3. Sleep Mode

Put the device to sleep manually to save power and increase the life time.

Short press the on/off button to put the device into hibernation or wake up the device.

4. Focusing

By manually adjusting the focus, you can make the image of the captured scene clear.

Manual Focus

Aim the lens of the device at the scene to be observed, and rotate the focus wheel next to the lens clockwise or counterclockwise to adjust the focus.

5. Storage

The device is equipped with a memory card for storing the captured photos.



Note

For detailed information, please refer to the actual memory card.

2. Thermal Image Display

1. Dropdown Menu

Users can swipe down from the top of the screen to bring up the system's drop-down menu. In this menu, users can toggle functions on or off or adjust settings through touch operations. When a function is turned on, its corresponding option will be highlighted. Users can quickly exit the drop-down menu by swiping up from the bottom of the screen.



2. Image Mode

The device captures infrared and visible light images. Users can select different image modes to meet various image display needs. The specific steps are as follows:

1. Live Interface: When the device is in IR mode, press the OK button or tap the main menu to bring up the device menu.
2. Device Menu → Image Mode
3. Select the desired image mode



2.1. Infrared Image Mode

This mode displays the infrared image.

2.2. T-DEF® Blend Mode

This mode allows you to view both thermal and visible real-time images at the same time. Users can adjust the IR image transparency from 0% to 100% by tapping the transparency value to display the adjustment slider and touching the screen to operate the adjustment slider. The slider can be hidden by tapping the transparency value again.



2.3. Picture-in-Picture

This mode superimposes an infrared image on a visible light image.

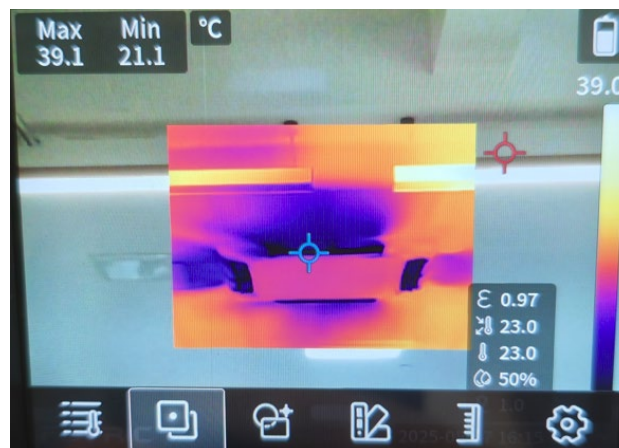

2.4. Visible Light Image

This mode displays a visible light image captured by a digital camera.



3. Palette

The device can change the color palette to display different image colors, allowing images of different scenes to be presented more clearly. The specific operation steps are as follows:

1. Live interface, press OK button/tap the main menu to call up the device menu
2. Device menu → Palette
3. Select the desired color palette

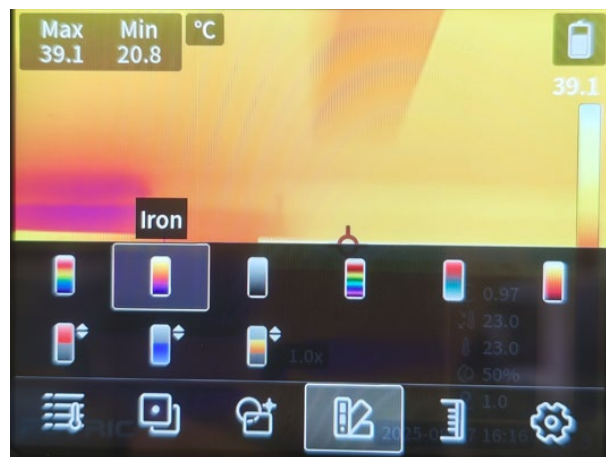

4. Color Alarm

The device supports color alarms above, below and between temperatures. That is, set the alarm threshold and display the alarm color for the temperature measurement target or object that meets the alarm conditions, so as to facilitate the discovery of abnormalities in the monitoring scene. The specific operation steps are as follows:

1. Live interface, press OK key/tap the main menu to call up the device menu

2. Device menu → Color palette

3. Select the color alarm type, set the alarm threshold, and then check if there is any abnormal situation

- 3.1 Above Temperature Alarm: Display all pixels with temperature above the alarm threshold in alarm color.

- 3.2 Below Temperature Alarm: Display all pixels with temperature below the alarm threshold in alarm color.

- 3.3 Between Temperature Alarm: Display all pixels with alarm color if the temperature is between the alarm thresholds.

5. Temperature Scale

The device temperature scale adjustment supports automatic and manual, modes. The specific operation steps are as follows:

1. Real-time interface, press OK key/tap the main menu to call up the device menu

2. Device menu→Temperature scale mode

3. Select temperature scale mode type

- 3.1 Automatic Temperature Scale: Adjust the upper and lower limits according to the global maximum and minimum temperature of the image.

- 3.2 Manual Temperature Scale: Adjust the upper and lower limits to the temperature close to the specific target in the image, and adjust the upper and lower limits individually or simultaneously to adjust the display effect of the image, i.e., when switching to the Manual Temperature Scale Mode, you can adjust the upper and lower limit values by sliding the wheel or pressing the up and down buttons; and you can also control the values by tapping the upper and lower limits to adjust the values individually or simultaneously.



6. Digital zoom

The digital zoom function of the device can control the zoom display of the image. The specific operation steps are as follows:

1. Tap the multiplier value (1.0x) on the touch screen to appear the multiplier sliding wheel
2. Adjust the zoom in and zoom out by touching the wheel.
3. Tap the magnification value to hide the adjustment wheel, or tap the magnification value again to wake up the magnification adjustment wheel again.



7. Image Overlay Information

The device can overlay information such as parameters, temperature,

etc. onto an image file.

7.1. Global Information Display

This setting is used to specify that the global maximum and minimum temperatures, and the maximum, minimum and average temperatures of the temperature measurement area are displayed superimposed on the image. The specific operation steps are as follows:

1. In the live interface, press the OK button/tap the main menu to call up the device menu.
2. Device menu → ROI → Display settings
3. Enable the overlay for the maximum temperature, minimum temperature, average temperature, and emissivity. The global information will be displayed based on whether the global option and the maximum/minimum temperature options are enabled.

7.2. Other Additional Information Display

This setting is used to specify the temperature measurement parameters, lens information, and date and time information to be displayed superimposed on the image. The specific operation steps are as follows:

1. In the real-time interface, press the OK button/tap the main menu to call up the device menu.
2. Device menu → Settings → Device Set → Overlay Information
3. Enable the content to be overlaid

8. Maximum and Minimum Temperature Tracking

The location of the highest and lowest temperature points in the global and regional areas can be automatically tracked with special markers on the device.

8.1. Global Maximum and Minimum Temperature Tracking

When the global maximum and minimum temperatures are superimposed on the image, the location of the global maximum temperature point is marked in red, and the location of the global minimum temperature point

is marked in blue.

8.2. Regional Maximum and Minimum Temperature Tracking

When the maximum and minimum temperatures of a region are superimposed on the image, the location of the region's highest temperature point is marked in red and the location of the region's lowest temperature point is marked in blue.

9. High Temperature Difference Equalization Imaging (T-TWB®)

This function optimizes the display of large dynamic range images to show more details. The specific operation steps are as follows:

1. Real-time interface, press OK button/tap the main menu to call up the device menu
2. Device menu→Setup→ Device Setup→Image Enhancement, Enable T-TWB®.

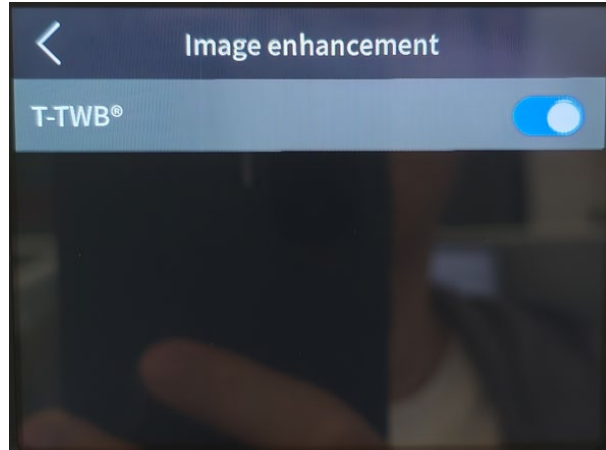

3. Measurement and Analysis

1. Temperature Measurement Range

The device supports different temperature ranges. To obtain accurate temperature measurements, the user needs to change the temperature range of the device so that it is suitable for the expected temperature of the object to be measured. The procedure is as follows:

1. In the live interface, press OK key/tap the main menu to call up the device menu.

2. Device menu → Settings→ Temp Measurement range

3. Select the appropriate temperature range

2. Global Temperature Measurement Parameters

To ensure accurate temperature measurements for different measured targets, please make sure to set the correct temperature measurement parameters. The specific operation steps are as follows:

1. In the live interface, press the OK key/tap the main menu to call up the device menu.

2. Device menu→Parameters→ Emissivity, change the corresponding parameter according to the measured object, refer to Appendix A. emissivity table.

3. Device menu → Parameters→ Reflected temp, when there is a high-temperature target in the scene, if the emissivity of the DUT is small and reflects the high-temperature target, the reflected temperature should be set to the temperature value of the high-temperature target.

4. Device menu→Parameters→ Ambient temp, change the corresponding parameters according to the current observation environment.

5. Device menu→Parameters→ Humidity, change the corresponding parameter according to the current observation environment.

6. Device menu→Parameters→ Distance, change the corresponding parameter according to the distance between the measured object and the device.

7. Device menu→Parameters→ IR Window Compensation, change the corresponding parameters, you can set the on/off state, as well as the temperature and transmittance rate.

3. Measurement Tools(ROI)

The device can set a spot, line or box for the location, boundaries or area of interest for temperature measurement.

3.1. Add Spots

The specific operation steps are as follows:

1. Real-time interface, press OK button / tap the main menu to call up the device menu
2. Device menu→ROI→ Add a spot
3. Tap to select the spot and drag to adjust its position.

3.2. Add Rectangle

The specific operation steps are as follows:

1. In the live interface, press OK key/tap the main menu to call up the device menu.
2. Device menu→ROI→ Add Rectangle
3. Touch to select the box, drag and move to adjust the position of the box.
4. Touch the four vertices of the box, and drag to adjust the size of the box.

3.3. Add Line

The specific operation steps are as follows:

1. In the live interface, press OK key/tap the main menu to call up the device menu.
2. Device menu → ROI→ Add line
3. Select the line and drag it to adjust the position of the line.
4. Tap both ends of the line and drag to adjust the size of the line.

4. Regional Emissivity Correction (Partial Emissivity)

The device supports to set the emissivity of each temperature

measurement area individually, so as to realize the accurate temperature measurement by area. The procedure is as follows:

1. In the live interface, select the temperature measurement spot/line/rectangle to enter the temperature measurement object interface.
2. Press OK key/tap the menu of temperature measurement object, menu of temperature measurement object→emissivity.
3. Change the corresponding parameters according to the measured target, refer to Appendix A. Emissivity Table.

5. Analyzing Software

AnalyzIR professional thermal image analysis software, specific operation details see the user manual of the analysis software.

4. Basic Parameters

1. Focusing

Focusing allows the device to capture a clearer image.

1.1. Manual focus

Manual focus is done by manually rotating the focusing ring.

5. Capture Functions

1. Single Frame Capture

Take a picture in the live interface with the capture button and save it in the device's storage card.

1.1. File Naming Format

Named by Date & No.

1. In live interface, press OK button/tap Main Menu to bring up the device menu;

-
2. In Device menu→Settings→Storage and save option, choose file naming format: **Named by Date & No.**;
 3. Complete a single-frame capture (File name: Named by Date & No). Go to the gallery → Image preview → File properties, and check the file name: Named by Date & No.

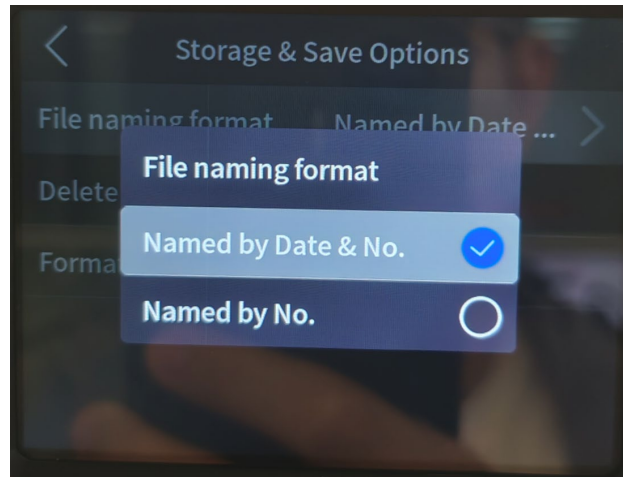

Named by NO.

1. In live interface, press OK button/tap Main Menu to call up the device menu;
2. In Device menu→Settings→Storage and save option, choose file naming format: **Named by NO.**;
3. Complete a single-frame capture (File name: Named by Date & No). Go to the gallery → Image preview → File properties, and check the file name: Named by No.

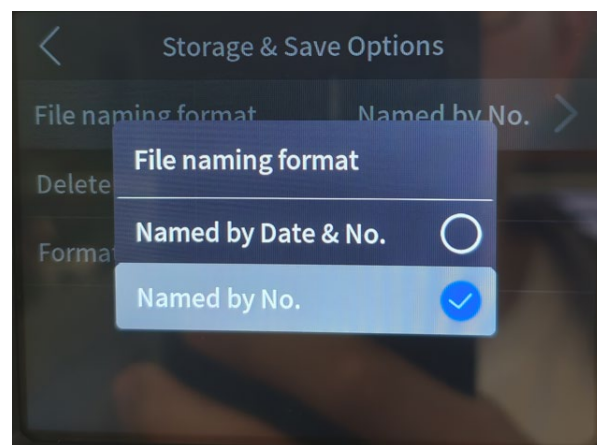

2. Gallery

The files are saved on the SD storage card, and the user can view all the saved files through the gallery.

Operation Steps:

1. Press the Gallery button on the device to enter the gallery interface.
2. Press the Back button on the device to return to the live view interface.

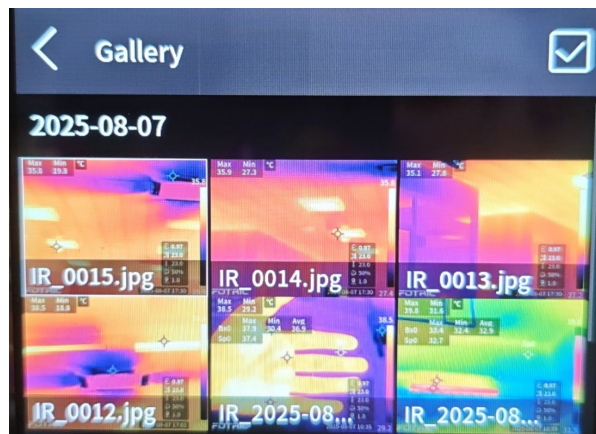

Delete

1. Click the selection icon on the top of the gallery;
2. Select one or more files and click the delete icon above the gallery;
3. Click OK button, the selected files are deleted successfully.

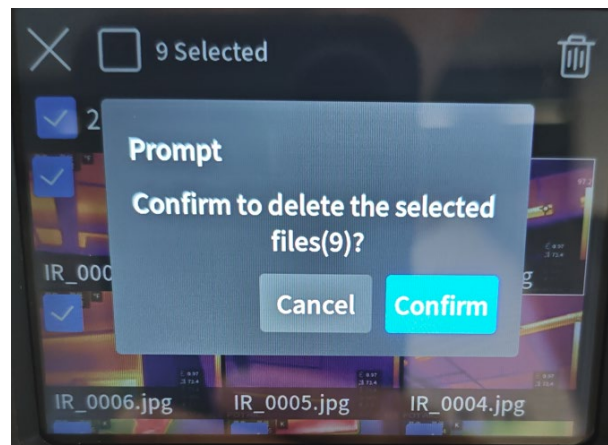

Gallery Preview

The thermal image has been selected, touch the thermal image/press OK

button to enter the gallery preview interface.



Delete Function:

Click the Delete button, the image is deleted successfully.

6. Data Connection

1. USB interface

The device can be connected to a computer using a USB cable. Once the connection is established, image and video files can be transferred from the storage card to the computer.

7. Auxiliary Functions

1. Laser

Supports laser pointer.

Operation steps:

1. Click the laser button on the device to turn on the laser;
2. A laser point will be visible on the target, and the screen will display the symbol along with the laser measurement distance.
3. Release the laser button to turn off the laser.

2. LED Lamp

Support for **Flashlight illumination** and **Flash mode**.

Flashlight Illumination:

Open the device's flashlight from the main menu interface drop-down menu and use it as a flashlight.

Flash mode:

1. Real-time interface, press OK button/tap the main menu to call up the device menu;
2. Device menu → Settings → Device Set → Turn on the 'LED light as flash' .

3. Languages

Supported languages include: Simplified Chinese and English.

Operation steps:

1. On live interface, press OK button/tap the main menu to bring up the device menu;
2. Device menu → Settings → Device Set → Language&Time&Region → Language;
3. Select a language to switch to that language.

4. Software and Firmware Upgrade

Support firmware offline upgrade.

Firmware Offline Upgrade

1. Make sure The .zip file of the upgrade package has been placed in the memory card of the device;
2. Live interface, press OK button/tap the main menu to bring up the device menu;
3. Device menu → Settings → Device set → About → System Update;
4. Tap System Update to discover the available upgrade version;
5. Tap the Update button, the system carries out the upgrade operation,

the device reboots after the upgrade is complete.

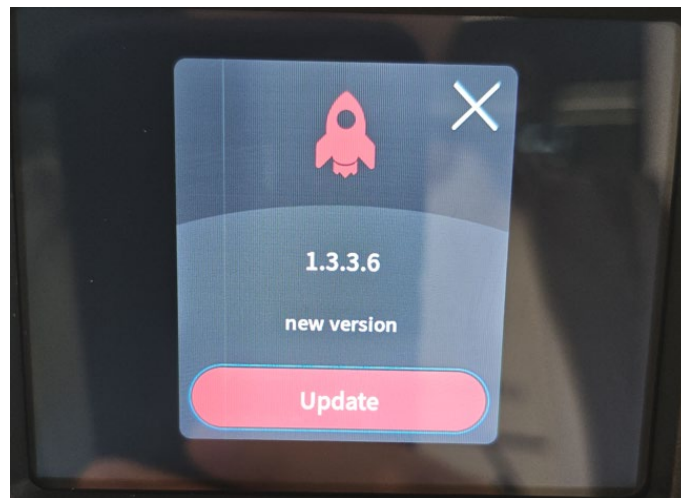

5. Device Set

Used to set Overlay information, Image enhancement, Language&Date&Region, Screen brightness, LED as flash, Auto power off time, Reset, and About.

Overlay information

This setting is used to specify the temperature measurement parameters, lens information, and date and time information to be displayed superimposed on the image. The specific operation steps are as follows:

1. In the live interface, press the OK button/tap the main menu to call up the device menu.
2. Device menu→Setup→Device set→Image overlay information.
3. Enable the content to be superimposed

Image Enhancement: Please refer to 2.9. High Temperature Difference Equalization Imaging (T-TWB®)

Language&Time&Region

Set the language, temperature unit, distance unit, date, time, time zone, and time format.

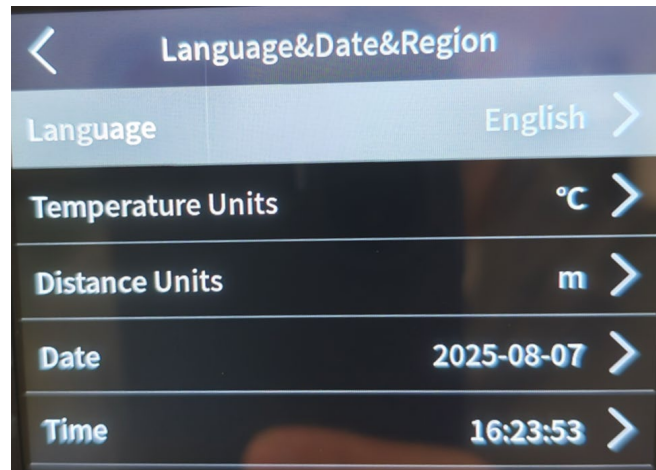

To set the language: Refer to 7.3 Languages.

Setting the temperature unit

1. Live interface, press OK button/tap main menu to call up the device menu;
2. Device menu → Setup → Device Se → Language&Time&Region → Temperature Unit;
3. Set temperature unit.

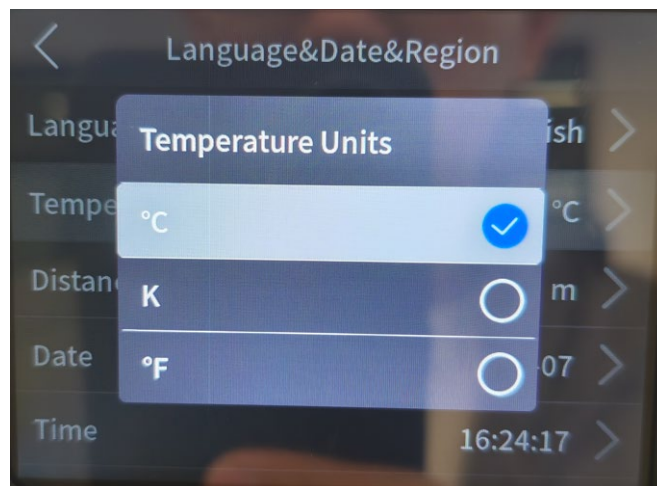

Setting distance unit

1. Live interface, press OK key/tap the main menu to call up the device menu;
2. Device menu → Settings → Device set → Language&Time&Region → Distance unit;
3. Set the distance unit.

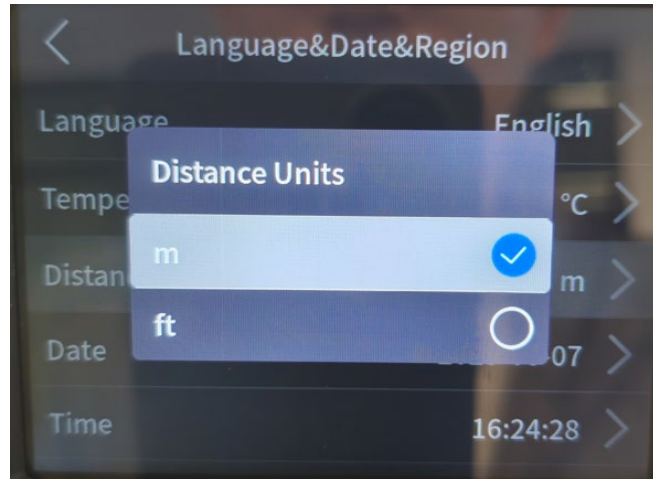

Setting the date

1. Live interface, press OK key/tap the main menu to call up the device menu;
2. Device menu → Settings → Device set → Language&Time&Region → Date;
3. Set the date parameter.

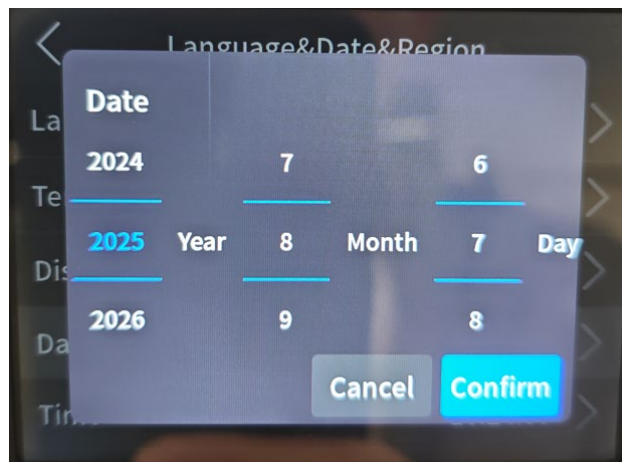

Setting Time

1. Live interface, press OK key/tap the main menu to call up the device menu;
2. Device menu → Settings → Device set → Language&Time&Region → Time;
3. Setting the time parameters.

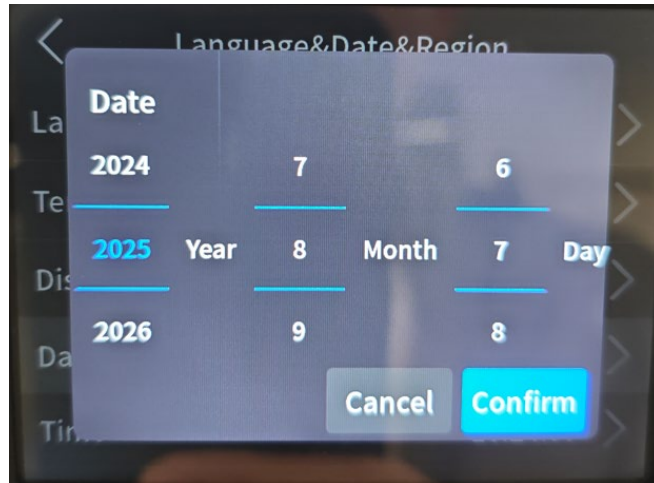

Setting the time zone

1. Live interface, press OK key/tap the main menu to call up the device menu;
2. Device menu → Settings → Device set → Language&Time&Region → Time zone;
3. Set the time zone parameter.

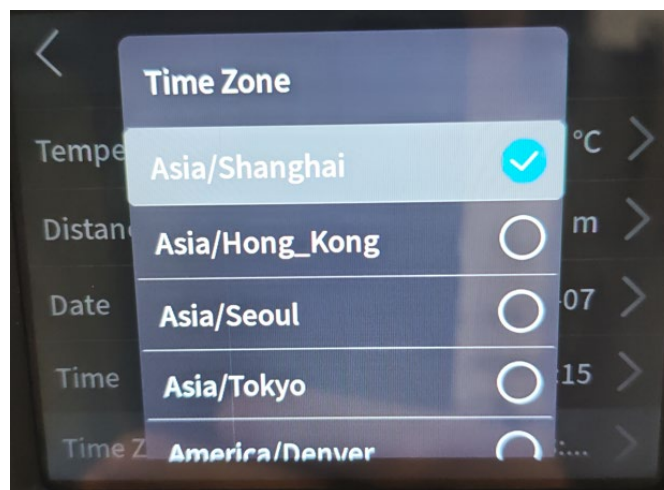

Setting the date format

1. Live interface, press OK key/tap the main menu to call up the device menu;
2. Device menu → Settings → Device set → Language&Time&Region → Date Format;
3. Set date format parameters.



Adjust Screen Brightness

1. Live interface, press OK key/tap the main menu to call up the device menu;
2. Device menu → Settings → Device set → Screen brightness;
3. Slide the screen to adjust the screen brightness.



LED as flash: please refer to 7.2.

Rest time

1. Live interface, press OK button/tap main menu to call up the device menu;
2. Device menu→Setup→Device Set→Screen Off Time;
3. Set the rest time, i.e. after how long the device is not operated, the device will rest automaticall.



Automatic shutdown time

1. Live interface, press OK button/tap the main menu to call up the device menu;
2. Device menu→Setup→Device set→Automatic shutdown time;
3. Set the auto power off time, i. e., after how long the device is not operated, the device will be shut down automatically.

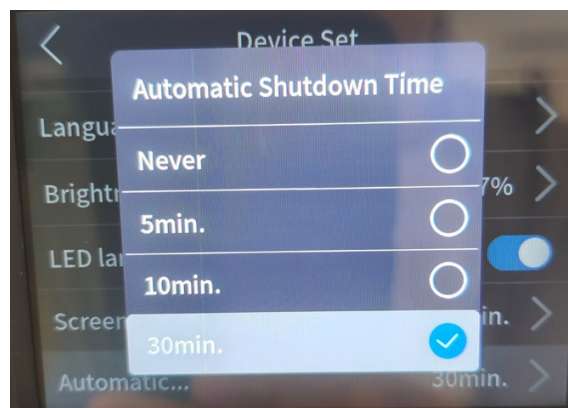

Reset

The parameters can be reset to the factory default settings.

About

The user can check the model number, serial number, firmware version, lens, battery level, remaining capacity of the memory card, system update.

The image shows a screenshot of the 'About' page on a device. The page has a dark background with white text. At the top left is a back arrow icon, and at the top center is the title 'About'. Below the title is a list of system information items, each with a label on the left and a value on the right, separated by a thin white line. The items are: MODEL (Fotric TK6), Serial Number (0702006434), Firmware Version (1.3.3.6), Lens (15mm L25), and Battery Level (61%).

About	
MODEL	Fotric TK6
Serial Number	0702006434
Firmware Version	1.3.3.6
Lens	15mm L25
Battery Level	61%

Emissivity Table

(for reference only)

Material Name	Surface Condition	Temperature(°C)	Emissivity(ϵ)
Aluminum	Non-oxidized	100	0.20
	Oxidized	100	0.55
Brass	Polished brown	20	0.40
	Unpolished	38	0.22
	Oxidized	100	0.61
Copper	Severely oxidized	20	0.78
Iron	Oxidized	100	0.74
	Rusty	25	0.65
Cast iron	Oxidized	200	0.64
	Non-oxidized	100	0.21
Wrought iron	Roughened	25	0.94
	Polished	38	0.28
Nickel	Oxidized	200	0.37
Stainless steel	Oxidized	60	0.85
Steel	Oxidized at 800°C	200	0.79
Common brick	Surface	20	0.93
Concrete	Surface	20	0.92
Glass	Polished plate	20	0.94
Lacquer	White	100	0.92
	Natural color black	100	0.97
Carbon	Smoke black	25	0.95
	Candle soot	20	0.95

	Graphite rough surface	20	0.98
Paint	Average of 16 colors	100	0.94
Paper	White	20	0.93
Sand	Surface	20	0.90
Wood	Polished	20	0.90
Water	Distilled water	20	0.96
Skin	Human	32	0.98
Pottery	Fine	21	0.90
	Abrasive	21	0.93