

NOVAplus USER MANUAL



Producer:



MRU GmbH, Fuchshalde 8 + 12, D-74172 Neckarsulm-Obereisesheim
Phone +49 71 32 99 62-0, Fax +49 71 32 99 62-20
email: info@mru.de * site: www.mru.eu

Managing director: Erwin Hintz
HRB 102913, Amtsgericht Stuttgart
USt.-IdNr. DE 145778975

Legal notices / Intellectual property rights comments

Original user manual

© 2023 by MRU

No part of this manual may be published in any form (print, photocopy, electronic media or any other publication form) without a written approval by the publisher.

All user trade marks and name mark descriptions, even those which are not marked as such, are properties of the respective owners.

Edition: 2024-06-03-V1.14.EN

Table of content

1 Information for product and safety7

1.1. Safety manual7

1.2. Safety precautions.....7

1.3. Ensure safety8

1.4. Important general information EN 50379 and VDI 4206.....9

1.5. User guideline for rechargeable batteries.....9

2 Introduction 10

2.1. Intended use 10

2.2. About us..... 12

2.3. Packaging..... 13

2.4. Return of hazardous materials 13

2.5. Return of electronic equipment 13

3 Description 14

3.1. Measurement principle 15

Gas flow diagram with condensate separator 15

Gas flow diagram with gas cooler 16

3.2. Remote control unit (RCU)..... 17

3.3. Base unit condensate separator 18

3.4. Base unit with condensate separator 19

Connectors depending on the options (condensate separator) 20

3.5. Base unit with gas cooler (option) 21

Connectors depending on the options (gas cooler) 22

Water stop (option) 22

3.6. Gas sampling probes..... 23

4 Operating 24

4.1. Display 24

4.2. Keypad..... 25

4.3. Connection Remote control unit (RCU) to base unit 26

Declaration of symbols 26

Connecting base unit to RCU..... 26

4.4. Reset and Blink codes..... 28

4.5. Menu structure 28

5 First usage 30

5.1. Preparatory steps..... 30

5.2. Analyser settings..... 30

5.3. Measurement settings 31

5.4. Switch-On protection..... 32

5.5. Print-out settings 32

5.6. Bluetooth settings..... 33

5.7. Setting date and time..... 33

5.8. Configuring Measurement Programs 34

5.9.	Setting CO limit value	34
5.10.	Select fuel types and O ₂ reference.....	35
	Adding fuels to Fuel type selection	35
	Setting O ₂ reference.....	36
5.11.	Defining user fuels type	36
5.12.	Defining measurement window.....	37
5.13.	Configuring zoom window	38
5.14.	Changing measurement program names.....	39
6	Preparing measurement	40
6.1.	Ensure power supply.....	40
6.2.	Automatic Auto-off function	40
6.3.	Measuring with grid power supply / Battery charging.....	40
6.4.	Battery charge condition	40
6.5.	Operating temperature	41
6.6.	Controlling Condensate separator (water trap).....	41
6.7.	Connections and tightness	42
6.8.	Automatic zero-point setting	42
	Repeating the zeroing.....	43
6.9.	Zeroing with the 3-gas-NDIR bench.....	43
7	Performing measurement.....	44
7.1.	Selecting the measuring program.....	44
7.2.	Core flow search.....	45
7.3.	Measured value display.....	46
7.4.	CO purging (optional).....	48
7.5.	CO/H ₂ and CO high (optional).....	48
7.6.	Specific measurement applications	49
	30 sec. average value calculation according 1. BImSchV_2010.....	49
	Annular-gap measurement program.....	49
	Test program.....	50
	Performing Ambient CO Test.....	51
7.7.	Temporary buffer.....	51
	Store measured values in the buffer	52
	Overwrite measured values in buffer.....	53
7.8.	Storing measured values	53
	Entering T-boiler, Soot No. and Derivative.....	54
7.9.	Printing measurement values	55
7.10.	Terminate measurement	55
7.11.	Last measurement values	55
7.12.	Pressure measurement.....	56
7.13.	Differential temperature measurement	57
7.14.	Performing measurements on CHP units (option).....	57
8	Data Storage.....	59

8.1.	Organizing data storage.....	59
8.2.	Calling up information about data storage	59
8.3.	Site administration	60
	Create new site	60
	View sites	61
	Searching site.....	61
	Changing sites	62
	Deleting sites.....	63
	Data transfer using SD card (option).....	63
	Importing sites	64
	Exporting sites	66
	Exporting combustion measurements.....	66
	Exporting differential pressure measurements	67
8.4.	Measurements in Data storage	67
	Viewing Measurements	67
	Deleting measurements	68
	Transferring measurements to SD-Card (Option).....	69
8.5.	Data transfer to the PC (Sweeping district management pro-grams)	69
9	Extras / Adjustments	71
9.1.	User definable Logo print out	71
9.2.	Service calibration menu	73
9.3.	Default settings	74
9.4.	Service values RCU / Service values Base unit.....	74
9.5.	Performing leak test.....	76
9.6.	Contents SD card	77
9.7.	Contents Analyser info.....	77
	Options list remote control	77
	Options list base unit.....	78
9.8.	Self diagnostics.....	78
10	Maintenance and care	79
10.1.	Cleaning.....	79
10.2.	Maintenance.....	79
10.3.	Service messages	79
11	Appendix	80
11.1.	Technical data.....	80
	General data	80
	Bluetooth frequency range and output power	81
	Gas sampling and conditioning.....	81
	Measurement accuracy data	82
11.2.	Calculated values.....	87
	Data communication	89

11.3. Analysis and calculations	89
11.4. Fuel type list.....	90
11.5. Text input	91
11.6. Asking user for decision	91
11.7. Firmware update	92
11.8. Troubleshooting	94
Troubleshooting the analyser	94
Troubleshooting condensate separator	94

1 Information for product and safety

1.1. Safety manual

All general information and safety precautions of MRU products are listed in the supplied separate safety manual.

Therefore, this manual must be read and observed before the first use of the instrument.

Instrument-specific safety and warning requirements in this manual are prefixed before dangerous actions.

1.2. Safety precautions

The used categories of safety precautions are here explained once more



⚠ DANGER

Identifies an immediate, impending hazard that, if ignored, will result in severe bodily injuries or death.



⚠ WARNING

Identifies an immediate, impending hazard that, if ignored, may result in severe bodily injuries, material damage or death.



⚠ CAUTION

Identifies a possibly dangerous situation that, if ignored, may result in minor injuries.



ATTENTION

Identifies a possibly harmful situation that, if ignored, may result in damages to the device or its surroundings.



NOTE

Identifies user tips and other especially important information.

The explanation of safety notices:



⚠ CAUTION

HOT – danger of burns and fire hazards from gas extraction probe.

Physical harm and property damage can be caused.

▶ Cool down the probe tube.

1.3. Ensure safety

- ▶ Please read the user manual completely before the first use.
- ▶ Only use the analyser for the intended use and within the parameters specified in the technical data.
- ▶ Do not use any violence.
- ▶ Avoid falls.
- ▶ Do not put the analyser into use, if the housing, power supply unit or supply leads are damaged.
- ▶ Do not store the analyser together with solvents. Do not use desiccants.
- ▶ Only carry out maintenance and service work on this analyser as described in the User Manual. Observe the prescribed action steps.
- ▶ Operate the analyser only in closed, dry rooms and protect it from rain and moisture.
- ▶ When operating the analyser on mains power, operate it only with the mains adapter supplied
- ▶ The analyser must not be located in the immediate vicinity of open fire or great heat.
- ▶ Do not use the metal tube of the gas sampling probe or other metallic parts / accessories as electrical conductors.
- ▶ Do not use the analyser in or under water.
- ▶ The specified temperature range of the gas sampling probe must not be exceeded, otherwise the probe tube and temperature sensor will be destroyed.
- ▶ Moisture, being pumped out of the condensates trap can be slightly acidic.
In case of skin contact IMMEDIATELY: clean affected parts of the body. Avoid getting liquid in eyes. Please carefully clean all parts that come into contact with the condensates.
- ▶ After measurement, vent the analyser with ambient air and allow the probe to cool. A hot probe could cause burns or ignite flammable material.
- ▶ Electrochemical sensors are by their operating principle not only sensitive to the gas they are intended for, but for other gases as well. This cross sensitivity is compensated by MRU for the typical application of flue gas analysis. However, unusual high concentration levels of single gas components might lead to a reduced measurement accuracy of other gas components and to a temporary change of the sensitivity of sensors, which may require several hours recovery time.
Especially concentration levels as high as several % for single gas components may affect the measurement of other gas components at ppm level. Those applications need to be discussed with MRU in detail

1.4. Important general information EN 50379 and VDI 4206

This analyser is not designed to be used for continuous measurements.

Before using the analyser verify the condition of the various parts of the analyser, such as the probe, the ambient air conditions, the condensate separator, star filter and the connectors for damage and/or blockages.

When starting up the analyser it will take between 1 – 3 minutes to set to zero depending on the condition of the sensors and of ambient.

The minimum zeroing time of the analyser to achieve correct measurement values can be expected by 1.5 minutes!

Caution: Exposure to acids; aggressive gases such as sulphur; vapours such as thinners, gasoline, alcohol and paint, etc. can damage, reduce the life of, or destroy the sensors.

The life of the sensors depends on how they are used, maintained and treated. Typical average life expectations are: O₂ - 2 years; CO - 2 - 3 years and NO - 3 years.

The use of the analyser for regulatory purposes is subject to special regulations (for example a periodical examination of the analyser). Please obtain the appropriate regulations from your local responsible authority.

1.5. User guideline for rechargeable batteries



NOTE

The rechargeable batterie is installed inside the analyser and is not accessible to the end customer. However, the following instructions must generally be observed when handling lithium-ion rechargeable batteries.

- This rechargeable battery can only be used in this analyser.
- Do not throw the rechargeable battery into a fire, charge it at high temperatures and store it in a hot environment.
- Do not deform, short-circuit or modify the rechargeable battery.
- The rechargeable battery must not be used in or under water.
- Do not expose the rechargeable battery to strong mechanical forces and do not throw it.
- Do not cut or squeeze the connecting cables of the rechargeable battery.
- Do not connect the (+) contact to the (-) contact or metal.
- Non-observance of the above guidelines can cause heat, fire and explosions

2 Introduction

- This manual enables you to understand and safely operate this MRU Analyser.
- Please read this manual with great vigilance and get familiar with the product before using it.
- This analyser may only be operated by competent personnel and for its intended use.
- Please pay special attention to all safety directions and warnings to prevent personal injuries and damaging of the product.
- We can't be held responsible for any injuries and/or damages that occur by not following the instructions in this manual.
- Always keep the manual near you when working with the analyser, to be able to read instructions as needed. Please ensure to hand over all documents to when handing the analyser over to others.

2.1. Intended use

The main task of the analyser is in supporting the following applications:

- Precise control- and adjustment measurements for Gas-, oil or wood fired burners
- Flue gas measurement according to 1. BImSchV and KÜO

The CO sensor is protected with the automatic purging pump.

This analyser can be equipped with additional options and/or additional accessories to full fill multiple other measuring tasks such as

- Mobile Gas detector (Option HC-sniffer)
- Anemometer (Option Flow velocity, using either a Pitot tube or a vane)
- Hygrometer/Barometer (Option ambient humidity including temperature and barometric pressure)
- Leak testing device (Option external pressure sensor)

The multiple options and multiple connections possibilities of external sensors often replaces the need of additional measuring equipment(s). Ask our sales reps. for available options and accessories or check out our MRU website.

The wireless remote unit offers the user a variety of advantages while measuring. Especially in small rooms only the base unit will sit next to the boiler while the user can operate the unit from a distance. Precise ambient air temperature measurements can be done with either the base unit or remote unit (RCU). The RCU can also be used as a standalone measuring and data logging unit for differential temperature and differential pressure (and other optional functions). With the optional available gas cooler with automatic condensate draining pump the unit can also be used for long term measurements

The analyser is specifically not intended as a safety device or personal protective equipment.

The analyser should not be used as a warning device to warn people against the presence of harmful gases.

The analyser must be used according to instructions for the intended use.

Our analysers are checked according to the following regulations:

VDE 0411 (EN61010) and **DIN VDE 0701** before they leave the MRU GmbH factory.

MRU technical products are designed and manufactured according to **DIN 31000/ VDE 1000** and **UVV = VBG 4** of the professional guilds for fine mechanics and electrical engineering.

MRU GmbH assures that the analyser complies to the essential requirements of the legal regulations of the member states of the electro-magnetic compatibility (**89/336/EWG**)



▲ WARNING

Risk from manipulations to the measuring device

Operational safety hazard

- ▶ Modifications or changes to the measuring device are not allowed.
-

2.2. About us

The analyser is produced by the MRU GmbH in Neckarsulm, Germany (Founded in 1984), a medium sized company that specializes in developing, producing and marketing high quality emission monitoring analysers. MRU GmbH produces a wide range of instruments, from standard analysers up to tailor made industrial analysers.



Plant 1: Sales, Service, R&D



Plant 2 (Production)

Fuchshalde 8 + 12

74172 Neckarsulm - Obereisesheim

GERMANY

Tel +49 71 32 99 62 0 (Front office)

Tel +49 71 32 99 62 61 (Service)

Fax +49 71 32 99 62 20

Email: info@mru.de

Site: www.mru.eu

2.3. Packaging

Save the original carton and packing materials to prevent damage in transit in case you need to return the unit to the factory.

2.4. Return of hazardous materials

Waste Disposal/Returns/Warranty - MRU GmbH is required to accept the return of hazardous waste such as electro-chemical sensors that cannot be disposed of locally.

Hazardous waste must be returned to MRU prepaid.

2.5. Return of electronic equipment

MRU GmbH is required to accept the return, for proper disposal, of all analysers delivered after 13th of August 2005. Analysers must be returned to MRU prepaid.

3 Description

The main task of the analyser is in supporting the following applications:

- Precise control- and adjustment measurements for Gas-, oil or wood fired burners
- Flue gas measurement according to 1. BImSchV and KÜO

The CO sensor is protected with the automatic purging pump.

This analyser can be equipped with additional options and/or additional accessories to full fill multiple other measuring tasks such as

- Mobile Gas detector (Option HC-sniffer)
- Anemometer (Option Flow velocity, using either a Pitot tube or a vane)
- Hygrometer/Barometer (Option ambient humidity including temperature and barometric pressure)
- Leak testing device (Option external pressure sensor)

The multiple options and multiple connections possibilities of external sensors often replaces the need of additional measuring equipment(s). Ask our sales reps. for available options and accessories or check out our MRU website.

The wireless remote unit offers the user a variety of advantages while measuring. Especially in small rooms only the base unit will sit next to the boiler while the user can operate the unit from a distance. Precise ambient air temperature measurements can be done with either the base unit or remote unit (RCU). The RCU can also be used as a standalone measuring and data logging unit for differential temperature and differential pressure (and other optional functions). With the optional available gas cooler with automatic condensate draining pump the unit can also be used for long term measurements

3.1. Measurement principle

In The analyser draws a sample of the flue gases from the duct using a built-in gas pump through the probe is cleaned and dried using condensate separator with built-in filter and analyzes the extracted gas with electrochemical sensors.

Draft and temperature are measured at the tip of the sampling probe.

Gas flow diagram with condensate separator

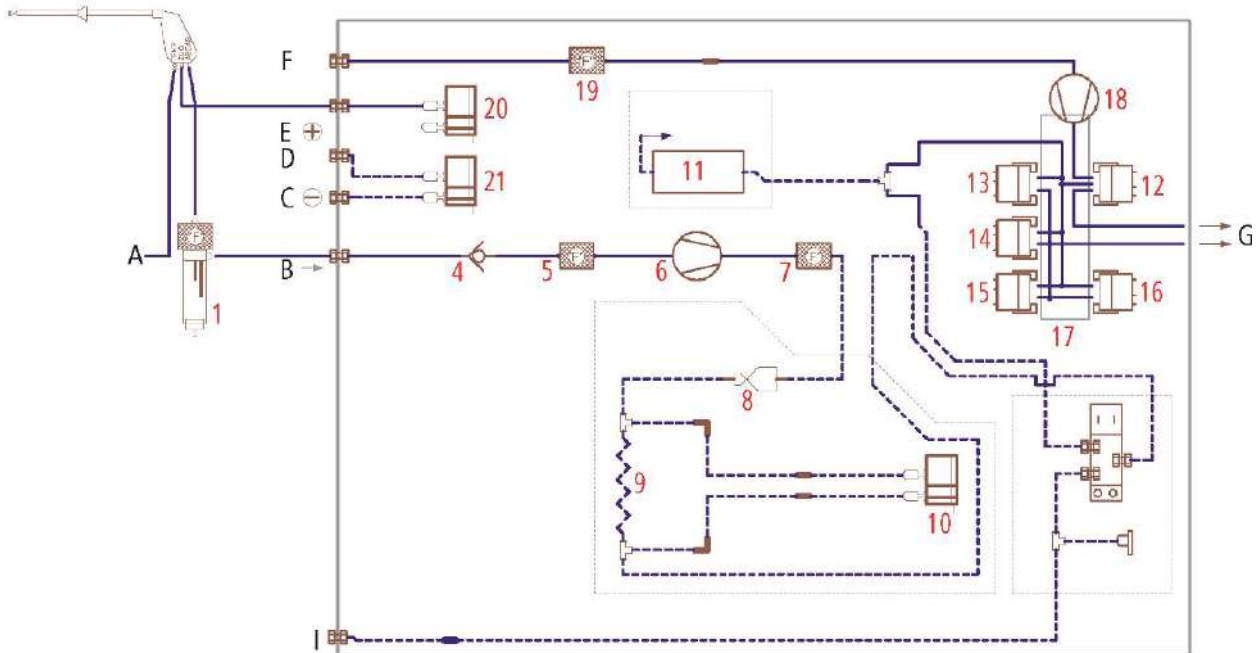

Position	Description	Position	Description
A	Gas temperature	6	Gas pump
B	Gas inlet	7	Filter
C	Differential pressure -	8	Nozzle
D	Differential pressure +	9	Capillary tube
E	Draft	10	Flow sensor
F	Fresh air inlet	11	NDIR bench
G	Gas outlet	12	O2 sensor
H	Not used	13	CO sensor
I	TRGI	14	NO sensor
		15	NO2 sensor
		16	SO2 sensor
1	Condensate separator	17	Sensor chamber
2	not used	18	Purge pump
3	not used	19	Filter
4	Non return valve	20	Pressure sensor
5	Filter	21	Pressure sensor

Gas flow diagram with gas cooler

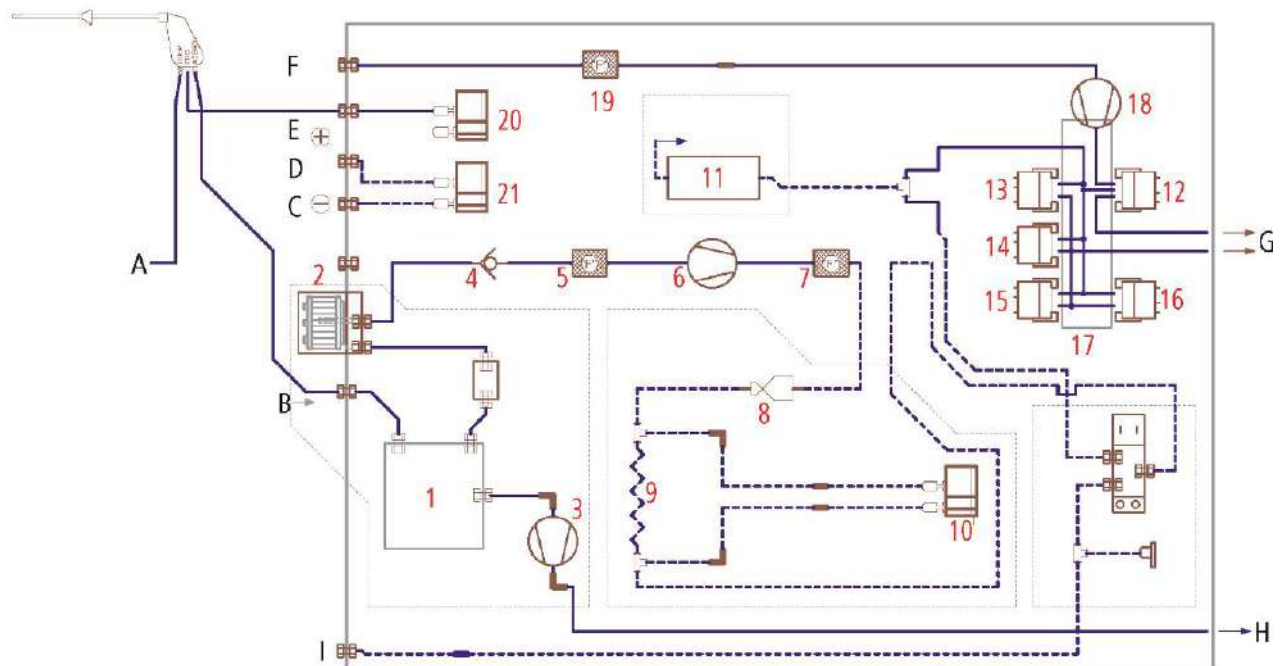

Position	Description	Position	Description
A	Gas temperature	6	Gas pump
B	Gas inlet	7	Filter
C	Differential pressure -	8	Nozzle
D	Differential pressure +	9	Capillary tube
E	Draft	10	Flow sensor
F	Fresh air inlet	11	NDIR bench
G	Gas outlet	12	O2 sensor
H	Condensate outlet	13	CO sensor
I	TRGI	14	NO sensor
		15	NO2 sensor
		16	SO2 sensor
1	Gas cooler	17	Sensor chamber
2	Star filter unit	18	Purge pump
3	Hose pump	19	Filter
4	Non return valve	20	Pressure sensor
5	Filter	21	Pressure sensor

3.2. Remote control unit (RCU)

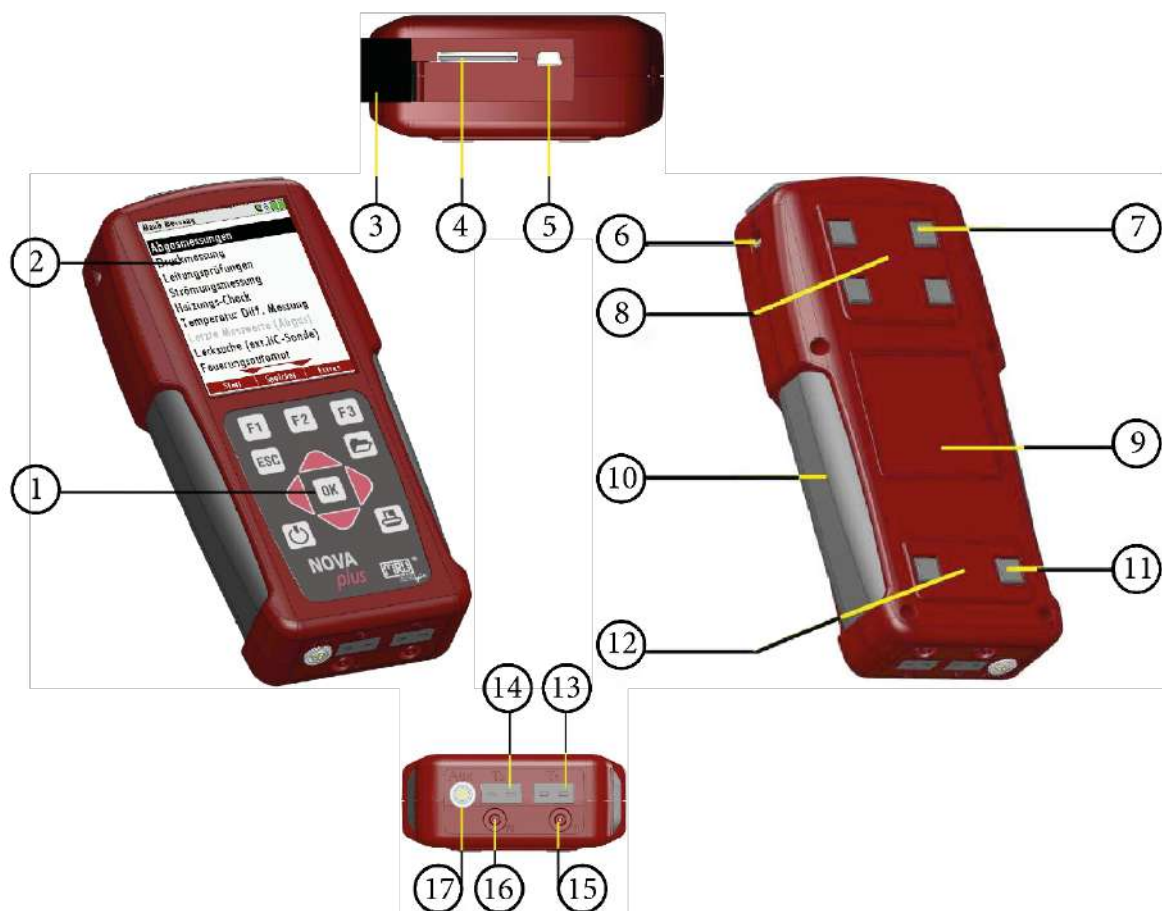

Position	Description	Position	Description
1	Keypad	2	Display
3	Cover	4	SD-card reader (only by using a MRU-SD-CARD we can assure the compatibility of all analyser functions)
5	USB port	6	Eyes for shoulder strap
7	Analyser feet	8	Fixing magnets
9	Contactless battery charging	10	Handle strip
11	Analyser feet	12	Fixing magnets
13	Temperature connection 1	14	Temperature connection 2
15	Pressure connection 1	16	Pressure connection 2 (Diff. pressure)
17	AUX connector		

3.3. Base unit condensate separator

• **CAUTION**



Condensate is acidic

The condensate from the container can be slight acidic and can cause chemical burn.

- ☞ Immediately clean with plenty of water once you have encountered acid

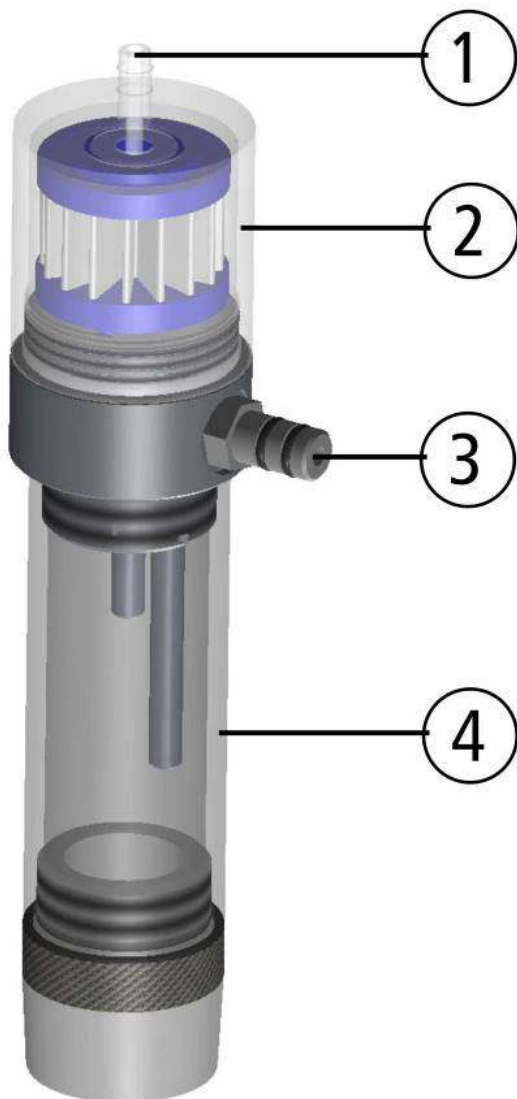

1 Disconnect the hoses at the gas entrance port (3) and the gas exit port (1).

2 Lift the condensate separator upwards out of the mounting bracket next to the base unit.

Liquid that is poured out of the condensate separator can be lightly acidic.

3 The condensate show glass and the bottom plug are screwed into each other and can easily be taken apart from each other (for cleaning and drying the condensate separator). The filter housing can also be unscrewed to replace the pleated filter. Please pay special attention when reassembling the condensate separator that all the O-Rings are in the right position and that they are not damaged. After each dismounting of the condensate separator we recommend you to perform an instruments leak proof test.

☞ See also chapter 9.5 Performing leak test, Page 76.

4 There is a pleated filter mounted in the condensate separator. This filter filters rough particles out of the flue gas. This pleated filter is washable and can be reused up to five times (filter must be completely dry before being used again). The filter should be replaced or washed when it changes its colour from to brown or grey. A frequently washed or replaced filter will avoid dirt getting inside the analyser will therefore avoid damage to your analyser.

3.4. Base unit with condensate separator

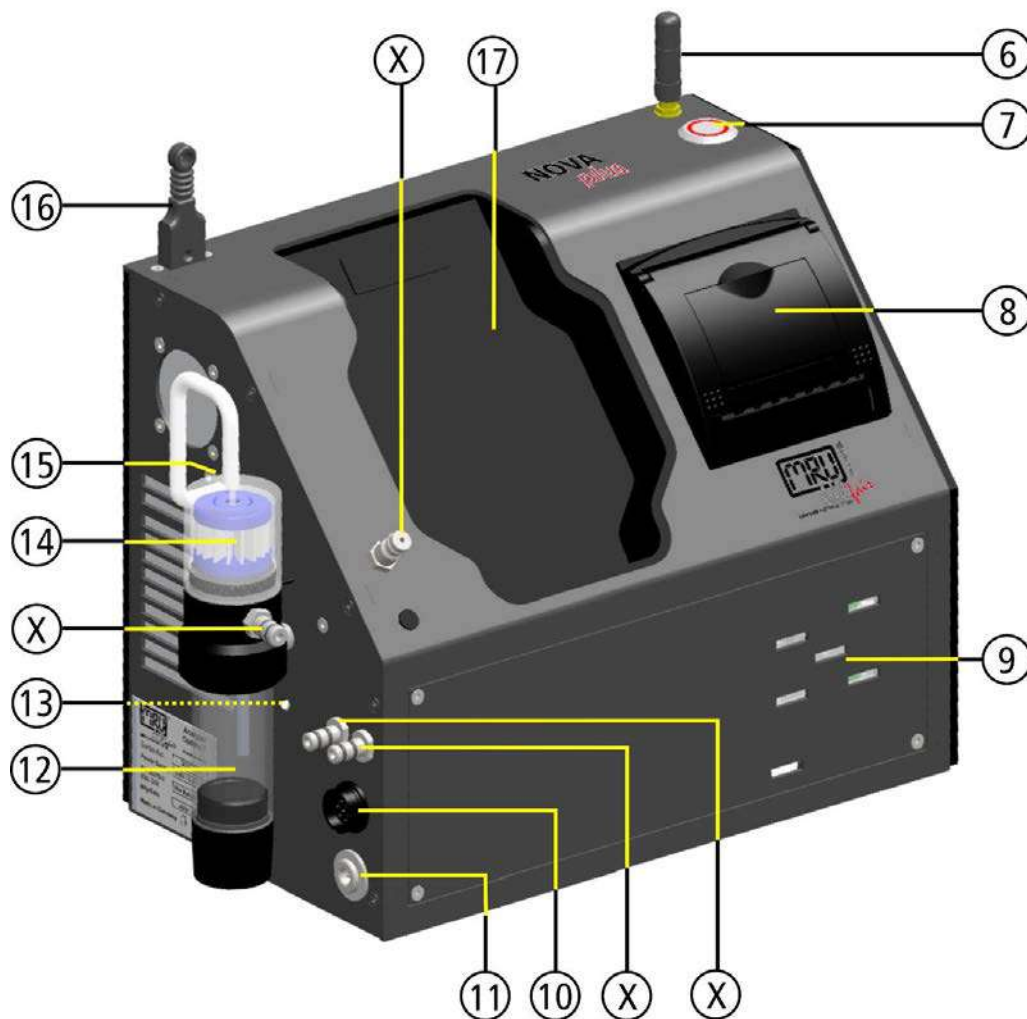

Position	Description	Position	Description
6	Aerial	12	Condensate separator
7	ON-/OFF key button	13	LED condensate separator
8	Built-in speed printer	14	Star filter
9	Gas outlet	15	Gas inlet after condensate separator
10	Connector T-gas	16	Connector T-Ambient air (combustion air)
11	Charging socket	17	Charging frame for Remote control unit
X	Connectors see also chapter Connectors depending on the options (condensate separator),Page 20		

Connectors depending on the options (condensate separator)



Connector	1	2	3	4	5
Models					
1 pressure sensor standard	gas inlet	draft / pressure -	pressure +		
TRGI Option pipe tests according TRGI	gas inlet	draft / pressure -	pressure +	TRGI	
2 pressure sensors Option Diff. Pressure measurement with 2nd internal pressure sensor	gas inlet	draft		pressure -	pressure +

3.5. Base unit with gas cooler (option)

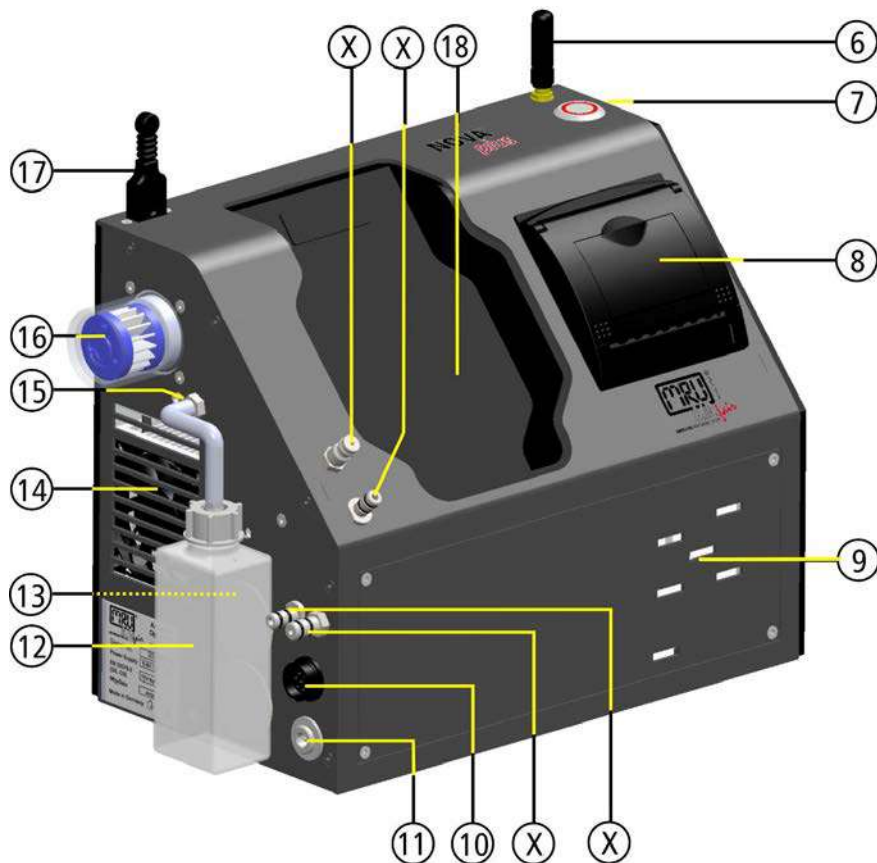

Pos.	Description	Pos.	Description
6	Aerial	13	LED condensate container
7	ON-/OFF key button	14	Fan gas cooler
8	Built-in speed printer	15	Outlet for condensate
9	Gas outlet	16	Star filter
10	Connector T-gas	17	Connector T-Ambient air (combustion air)
11	Charging socket	18	Charging frame for Remote control unit
12	Condensate container	X	Connectors see chapter Connectors depending on the options (gas cooler), Page 22

Connectors depending on the options (gas cooler)

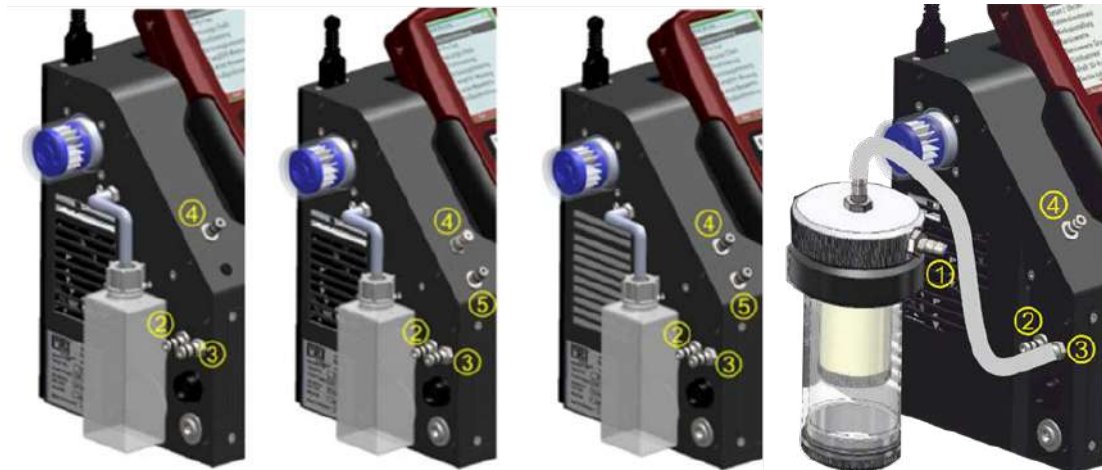

Connector	1	2	3	4	5
Models					
1 pressure sensor standard		draft/ pressure -	gas inlet	pressure +	
TRGI Option pipe tests according TRGI		draft/ pressure -	gas inlet	TRGI	pressure +
2 pressure sensors Option Diff. Pressure measurement with 2nd internal pressure sen- sor		draft/pressure -	gas inlet	pressure +	pressure +
<i>NOVApplus</i> "Smokehouse"	probe con- nector	draft/pressure -	gas inlet	Pressure +	

Water stop (option)

During operation, it can happen in certain device applications that water is sucked in. This filter reliably stops the water flow.

A closed water stop filter, for example, is recognizable by the fact that the flow is too low.

Replace the Acrodisk filter with the enclosed water stop dummy for operation without a water stop.

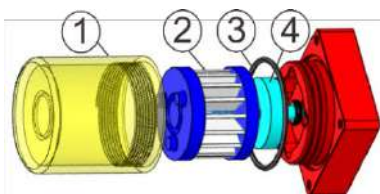

The Acrodisk filter with O-ring (4) can be changed after unscrewing the star filter housing cover (1) and removing the star filter (2). Replace the O-ring (4) of the star filter housing cover if necessary.

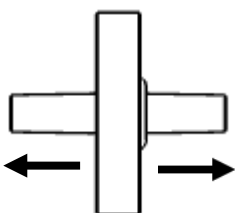

When installing the water stop filter, pay attention to the direction. The side with sealing ring must point to the NOVApplus. Due to the arrangement of the membrane in the filter, the water stop filter quickly becomes defective if incorrectly inserted due to too high pressure. The water stop should be replaced annually.

3.6. Gas sampling probes

The Analyser is available with different probes, both with fixed and exchangeable probe tubes.

A complete list of available probes can be found in the current price list of this analyser.

Below are two different probe types:

Probe

with 300 mm probe pipe (fixed)
and 2,7 m sampling line

Probe

with 300 mm exchangeable probe
pipe and 2,7 m sampling line

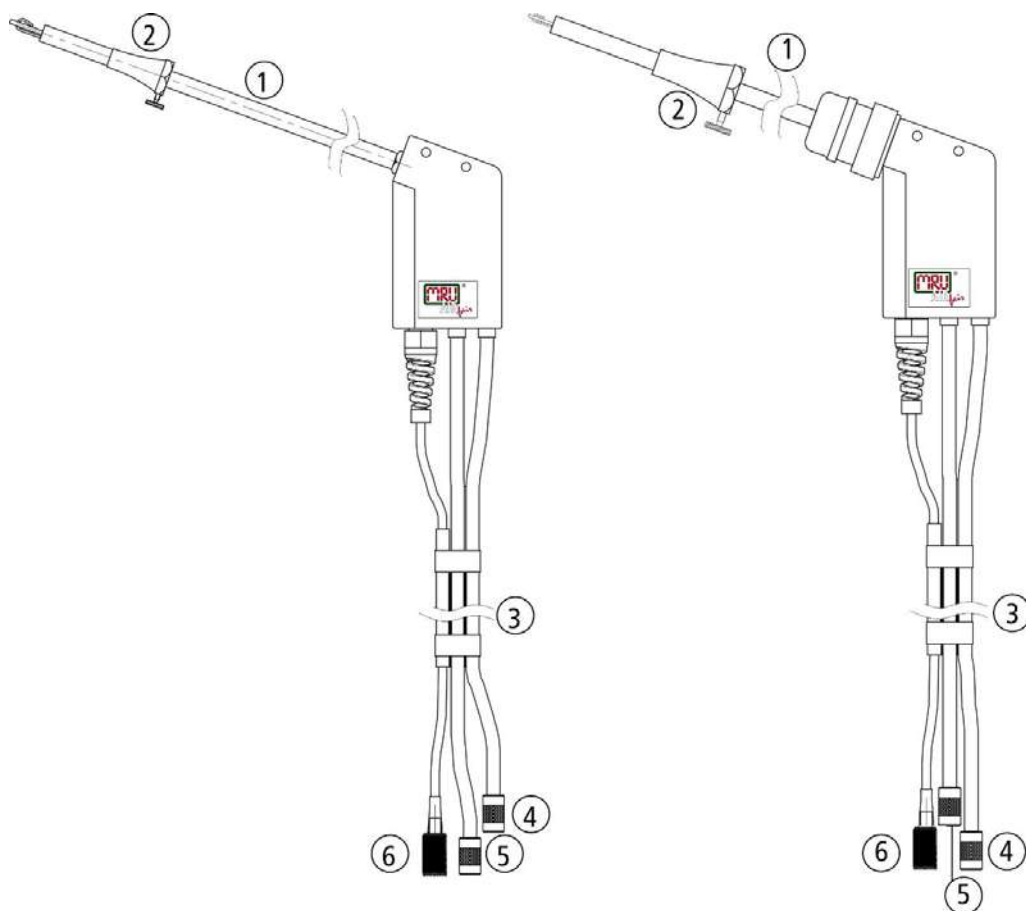

1	Probe tube
2	Probe cone (high grade steel)
3	Hose
4	Connector for sample gas measurement
5	Connector for draft measurement
6	Connector for temperature measurement

4 Operating

4.1. Display



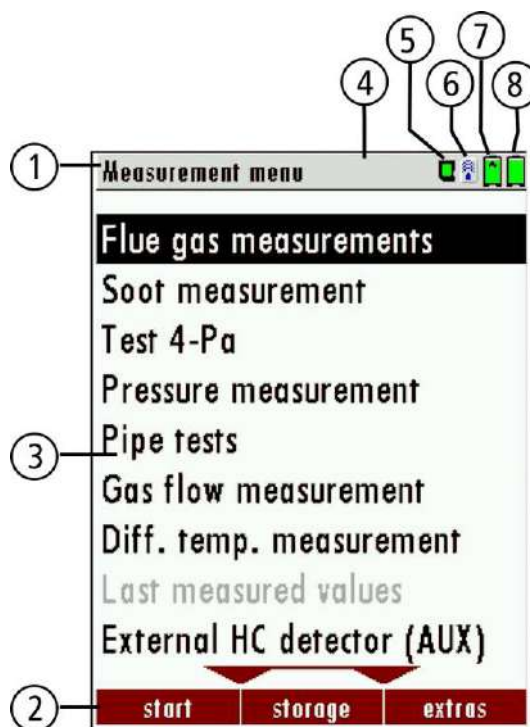



All information required to operate the analyser is displayed as shown below.



1	Menu bar
2	Function key bar
3	Display panel Menu Measurement value,
4	Zeroing active
5	SD-Card in the slot Indication green Read- and write access Indication yellow only Read access (SD-Card write protected) Indication red SD-Card is damaged SD-Card is damaged
6	Blue: Bluetooth connection base unit to RCU Red: No Bluetooth connection base unit to RCU Yellow: Base unit is in the update mode (Press ON-key at the base unit for changing to the measurement mode)
7	Battery charge condition base unit
8	Battery charge condition RCU



4.2. Keypad

Description and function of the keys:

ON / OFF		<p>By pressing the ON/OFF button the RCU will start up without delay.</p> <p>By pressing the ON/OFF button the base unit and the RCU (if RCU is placed in the charging doc) will start up.</p> <p>The powering down of the unit is timely delayed to protect the sensors if there is no fresh air inside the system. If there is no fresh air inside the system the analyser will recommend a purging of the sensors.</p>
Function Keys		Activates the functions seen on the display (2 function key bar).
Menu Key		Will show all available functions in the window that is currently in use – also those which have an individual key on the keypad like the printer and the three function keys.
ESC		Abort or return to the menu above
Arrow Keys		Jump in between lines, change values
OK		Confirmation key, select a marked menu point
Printer Key		Activates the print out of the measuring results in the measuring screen in a pre-defined format. Linefeed when there is no printable display condition:

4.3. Connection Remote control unit (RCU) to base unit

Declaration of symbols

Symbol	Description
	No Bluetooth connection base unit to RCU
	Base unit is in the update mode (Press ON-key at the base unit for changing to the measurement mode)
	Bluetooth connection base unit to RCU

If the connection breaks off base unit to RCU during a measurement, e.g., because of the distance, the symbol changes the colour from blue to red at the display of the RCU. The measurement in the base unit is not thereby broken off. As soon as the distance base unit to RCU decreases again the connection is rebuilt and the topical measuring values are indicated.

Connecting base unit to RCU

For connecting the RCU with the base unit select the menu settings/device info base

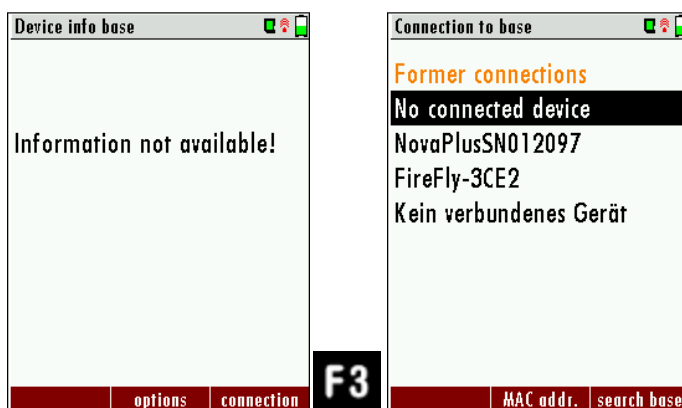

- ▶ Press F3.
- ▶ The menu Connection to base appears.
- ▶ Select an analyser from the list or search (F3) for basic devices in the immediate vicinity



NOTE

Connection menu (the connection remote control <-> base unit is preconfigured)

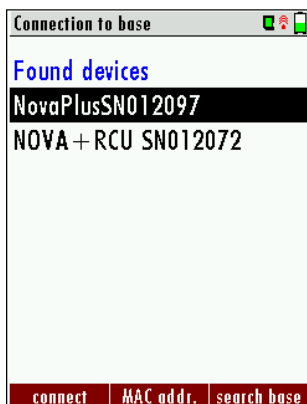

► Press F1, to connect to the base unit with the RCU.



NOTE

The name consists of NOVApplus and the serial number of the base unit.



MAC Adr.: display the Bluetooth address.

Search: All switched ON base units in the near environment will be displayed.

Delete list: Connection list will be deleted.

Disconnect: Existing connection will be disconnected with the F1

4.4. Reset and Blink codes

Reset of the RCU	press ESC and ON/OFF- button at the same time for a couple of seconds
Reset of the base unit	press ON/OFF- button for about ten seconds (LED switches off)
LED in ON/OFF- button in the base unit	
Illuminated constantly red	operating mode display
Flashes every five seconds	no connection with the RCU
Flashes every second	Software update active: Abort by using the ON/OFF-button

4.5. Menu structure

The analyser organizes all available actions in three main Menus:

- **Menu Measurement**

All available measurement options will be displayed and can be selected here

- **Menu Storage**

All available storage options will be displayed and can be selected here

- **Menu Extra**

All other actions are available here to manage and customize the device.

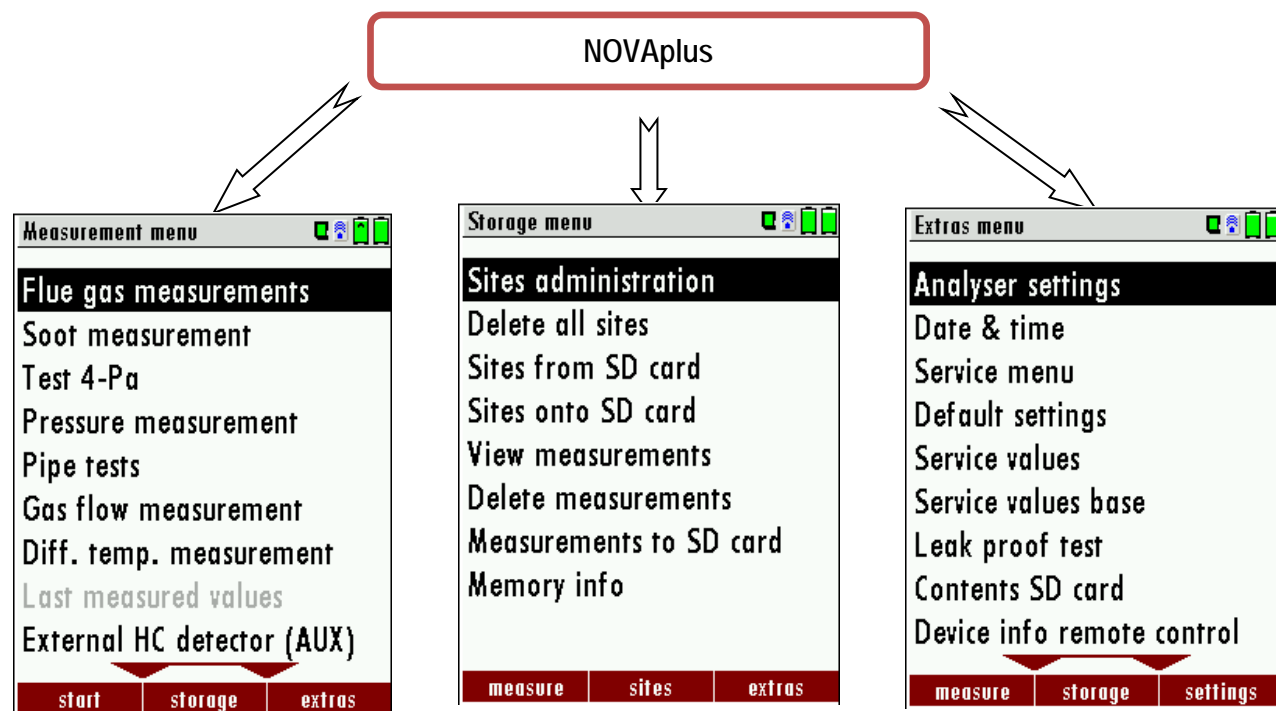

The topic „Flue gas measurement“ is a standard feature in every analyser and is explained in chapter 7 Performing measurement, Page 44. Other menu points are optional and will be explained either in this manual or in an additional manual or flyer.

The menu Storage is explained in chapter 8 Data Storage, Page 59.

The menu Extra is explained in Chapter 9 Extras / Adjustments, Page 71.

You can jump in between the 3 main menus with the 3 function keys (according to the displayed name on the screen).

5 First usage

After the analyser has been inspected and is ready for start-up it can be switched on and personalized settings can be entered. These settings can be changed at any time.

5.1. Preparatory steps

- ▶ Unpack the analyser.
- ▶ Read the User Manual completely.
- ▶ The analyser leaves the factory assembled and ready for use. Nevertheless, check the device for completeness and integrity.
- ▶ Charge the battery of the analyser for about 8 hours.
- ▶ Check date and time. Modify it needed.

5.2. Analyser settings

The "Settings" menu allows configuring some instrument specific parameters.

In the main menu "EXTRAS" = "F3 key" - scroll down to "Settings" then press the "OK" key. By selecting a line the parameter value can be changed by the arrow keys.

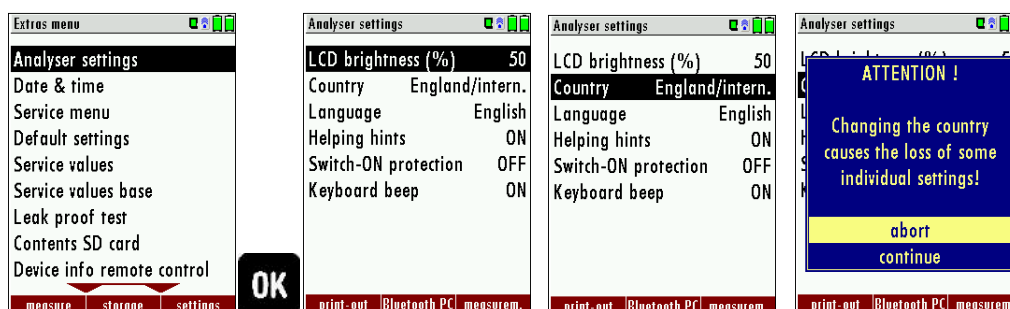

LCD brightness	5 – 100 %	Display-brightness, depending on the personal judgment of the user, at 20°C a value of ca. 50% is normal
Country	DE/GB/IT/FR/CZ/RO/TR / ES/NO/HU/NL/PL/SI/RU/LV/HR/JAP/	Enables some country specific parameters like fuel types, calculated values etc.
Language	DE/USA/GB/IT/AT/RO/ES/CZ/NO/TR/PL/HU/NL/FR/SI/RU/CH	Select device languages
Helping hints	ON / OFF	Helpful hints activated or deactivated (explanation below)
Switch ON protection	ON / OFF	If activated and if ON key is pressed (possibly inadvertently), then the message „3 seconds OK key press “ displays
Keyboard beep	ON / OFF	Keyboard beeper activated or deactivated

5.3. Measurement settings

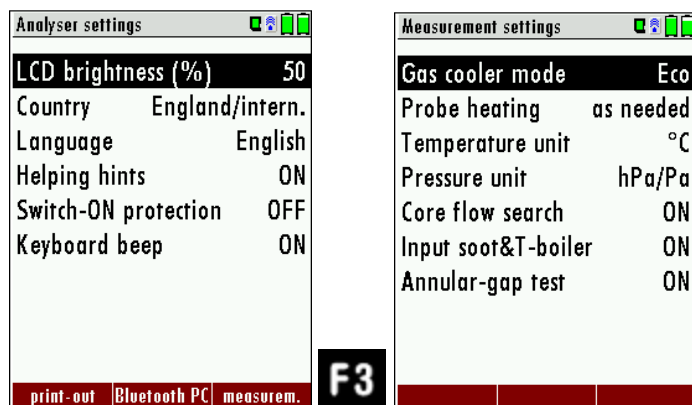

Gas cooler mode	Full / Eco	full: cooling up to approx. + 5 °C eco: cooling up to approx. 10 °C below ambient temperature (not under +5 °C!)
Probe heating	as needed / with mains	Probe heating is always switched on with mains, if the NOVApplus is connected to mains and is switched ON.
Temperature unit	°C or °F	Change the unit for temperature in all screens
Pressure unit	hPa/PA, hPa, kPa/Pa, kPa, mbar, mmH2O, cmH2O, in-chH2O, mmHG, in-chHG, PSI, Pa	Change the unit for pressure in all screens. The meaning of hPa/Pa and kPa/Pa is that the instrument performs a dynamic change of unit depending on the absolute value of pressure.
Core flow search	ON / OFF	Core flow search before start of each flue gas measurement: activated or deactivated
Input soot & T-Boiler	ON / OFF	Input soot and T-boiler values for print-outs and/or storage: activated or deactivated
Annular-gap test	ON / OFF	Annular-gap measurement: activated or deactivated

Explanation for "Helping hints":

Some helpful hints which are very useful for an inexperienced user but are not needed by experienced users, can be activated or deactivated. The following hints will be affected:

"Zeroing finished, Sensors are ready. Analyser ready for measurement."

"Reminder! Charge batteries at regular intervals!"

"Measurement stopped/started."

5.4. Switch-On protection

If activated and if ON key is pressed (possibly inadvertently), then the message: „3 seconds OK key press “displays.

5.5. Print-out settings

The printout can be set in the Extra menu under the menu item analyser settings.

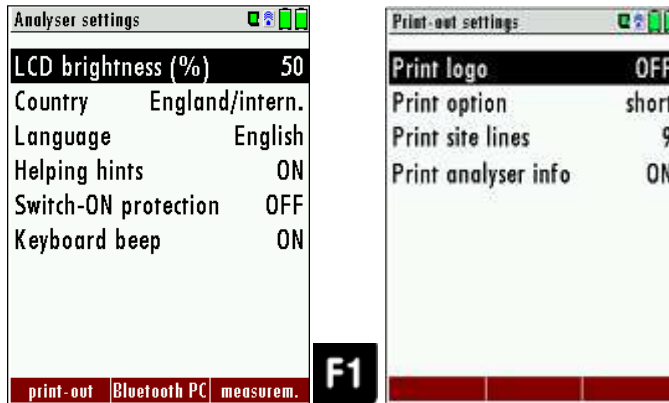

You can make the following adjustments in the menu Print-out settings:

Print logo ON/OFF	Print logo ☞ See also Chapter 9.1 User definable Logo print out, Page 71.
Print option short/long	Print-out without area for signature and site information
Print site lines 0...9	Line 1 (Site no.) is necessary, further lines (free text) printable if necessary.
Print analyser info	To measuring print out can be shorter designed, while the device info will be left out. In some print outs (adjustment, service ...) the info will be printed forever

5.6. Bluetooth settings

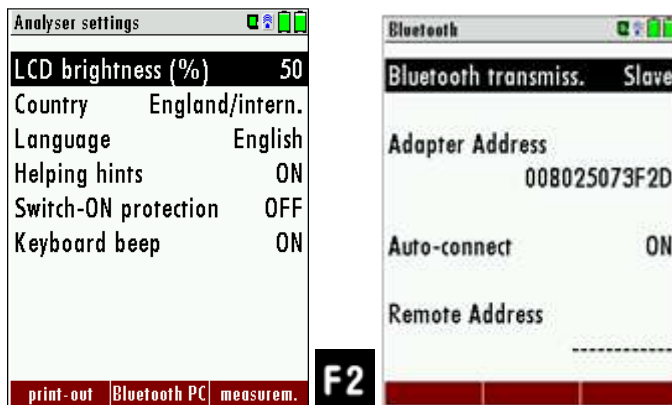

If RemoteData, OnlineView or MRUConnect (PDA) with Bluetooth is used, the SLAVE mode must be selected. The auto connect mode must be switched OUT.

5.7. Setting date and time

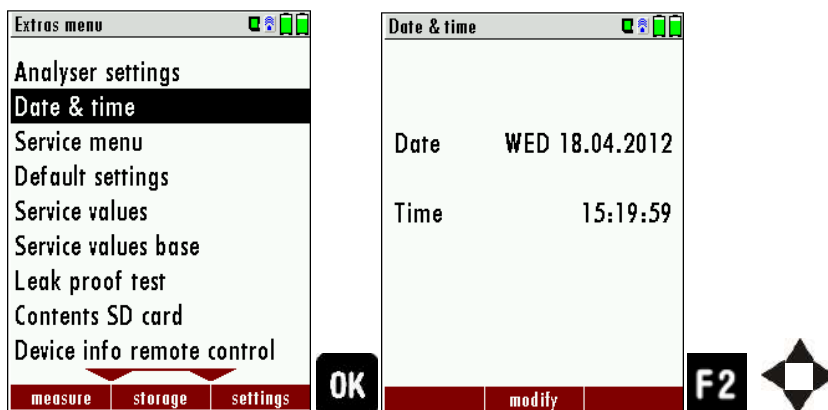

- ▶ Go to the Extras menu.
- ▶ Select Date and time.
- ▶ Press Ok.
 - ⇒ The Menu Date & time appears.
- ▶ Press F2.
- ▶ Set the desired date.
- ▶ Set the desired time.
- ▶ Press F2.
 - ⇒ The changes are stored.

5.8. Configuring Measurement Programs

(Flue gas measurements) Select one of the 6 configurable measurement programs.

For each of the programs the following parameters can be configured:

- CO ppm limit: adjustable value for the CO sensor protection. If the CO value in the flue gas is higher than the adjusted value in the analyser, the purge pump will be activated and the sensor will be protected against high CO concentrations. (Optional)
- Selectable fuel types: choose and select from the available fuel type list
- Measurement windows: configuration of what and where will be displayed in the 3 measurement value windows.
- Zoom – window: select what will be displayed in the zoom - window
- Program name

The following programs have a pre-configured:

- „Flue gas measurement“ with CO – limit of 2000 ppm
- „CO measurement“ with CO limit of 2000 ppm
- „Annular-gap test“ for pure O2 and CO – display
- „Test program“ indented for use at instrument maintenance and calibration, without fuel selection

5.9. Setting CO limit value

The CO ppm limit can be adjusted in the window „Measuring program selection“. Select one of the available programs (arrow up/down) then press the F1 key.

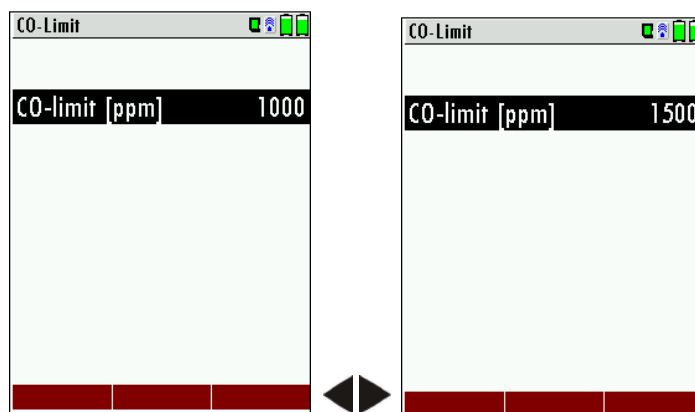

	The CO-ppm limit value can be adjusted in 100 ppm steps between 300 ppm and 4.000 ppm / 10.000 ppm
OK or ESC	Return to the measurement window

5.10. Select fuel types and O2 reference

Whenever a measuring program for flue gas measurements is called, a fuel can be selected from a list. Which fuel is available can be selected from a maximum fuel type list.

Adding fuels to Fuel type selection



- ▶ Select Gas measurements.
- ▶ Press OK
 - ⇒ The menu Selection meas. Program appears.
- ▶ Select the desired Measuring program.
- ▶ Press OK.
 - ⇒ The menu fuel type selection appears.
- ▶ Press OK.
 - ⇒ The menu Fuel type list appears.
- ▶ Select the fuel which should be added to the menu Fuel type selection.
- ▶ Press F1.
 - ⇒ The selected fuel is marked with a check mark.
- ▶ Select other fuels if necessary.
- ▶ Press OK.
 - ⇒ The selected fuel is displayed in the menu Fuel type selection.

Setting O₂ reference

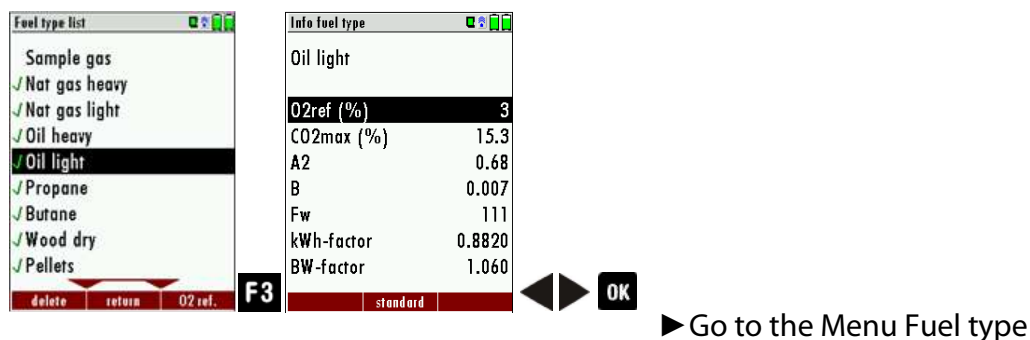

list.

☞ See also Chapter Adding fuels to Fuel type selection, Page 35.

- ▶ Select the desired fuel.
- ▶ Press F3
 - ⇒ The menu Info fuel type appears.
- ▶ Set the desired O₂ reference.
- ▶ Press OK.
 - ⇒ The set O₂ reference is saved.

5.11. Defining user fuels type

You can define four fuels to your individual needs. You can define the name and the fuel parameters. Like the other fuels, you can add user fuels to the menu Fuel type selection.

NOTE



The last 4 fuels in the menu Fuel type list are the user fuels. The user fuels are indicated in the menu Fuel Type list in green colour.

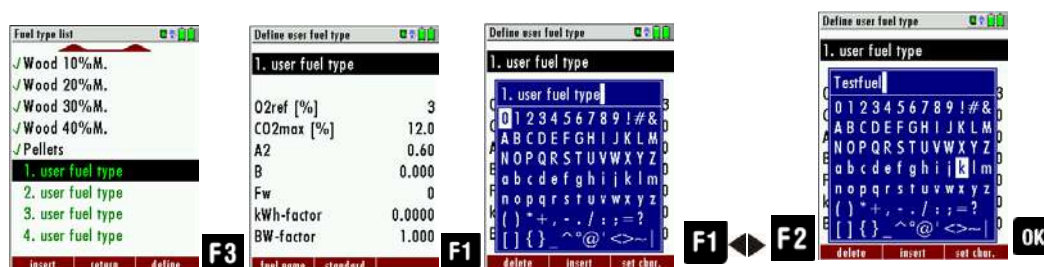

- ▶ Go to the menu Fuel type list
 - ☞ See also Chapter Adding fuels to Fuel type selection, Page 35.
- ▶ Select the user fuel you want to define.
- ▶ Press F3
 - ⇒ The menu Define user fuel type appears.
- ▶ Press F1.
 - ⇒ A window appears.
- ▶ Change the name of the user fuel to your needs
- ▶ Press OK
 - ⇒ The changed name is displayed in the menu Define user fuel type.
 - ⇒ After you have changed the name of the user fuel, you can define the fuel parameters.
- ▶ Select the desired fuel parameter.
- ▶ Change the desired fuel parameter.
- ▶ Press OK.
 - ⇒ The defined user fuel appears in the menu Fuel type list
 - ⇒ You can add the defined user fuel to the menu Fuel type selection.
 - ☞ See also Chapter Adding fuels to Fuel type selection, Page 35

5.12. Defining measurement window

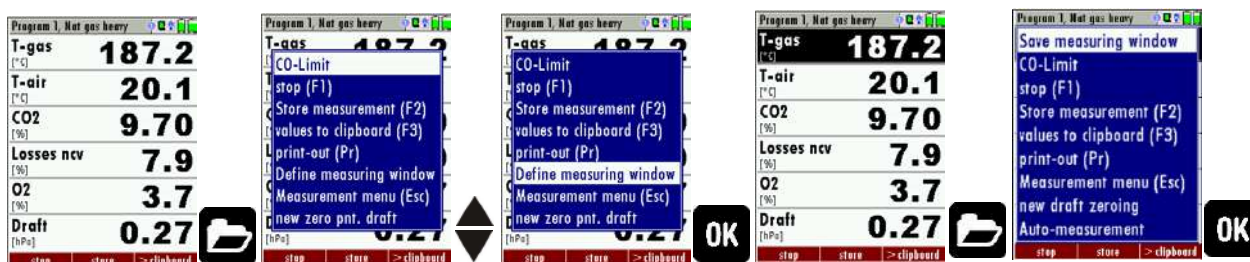

- ▶ Start a measuring program.
 - In this example Program 1, Nat gas heavy.
- ▶ Select one of three measurement windows
- ▶ Press the Menu Key
 - ⇒ A selection list appears.
- ▶ Select Define measuring window.
- ▶ Press OK.
 - ⇒ The measurement window appears.

- ▶ Select the desired measured value that you want to change.
- ▶ Press the Menu Key
 - ⇒ A selection list appears.
- ▶ Select Save measuring window.
- ▶ Press OK.
 - ⇒ The change is saved.

5.13. Configuring zoom window

Three zoom windows are available in each measuring program for the zoomed display of 2 measured values each. Which values are displayed zoomed is configurable.

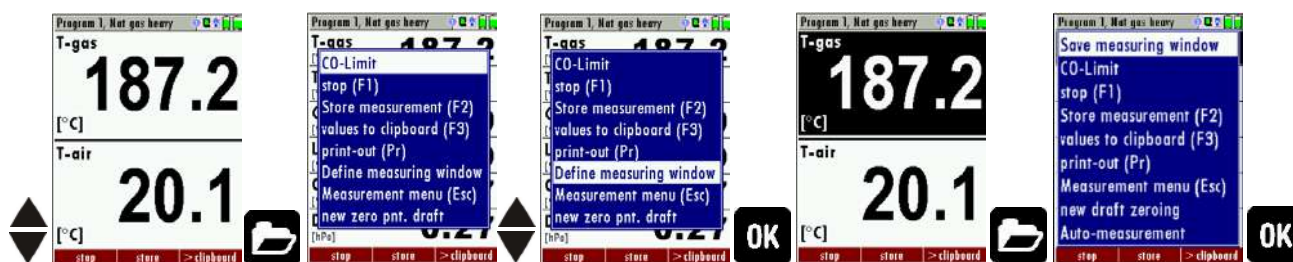

- ▶ Start a measuring program.
 - In this example Program 1, Nat gas heavy.
- ▶ Select the zoom function using the up / down arrow keys.
- ▶ Select one of three measurement windows.
- ▶ Press the menu key.
 - ⇒ A selection list appears.
- ▶ Select Define measuring window.
- ▶ Press OK.
- ▶ Select the desired measured value that you want to change.
- ▶ Press the Menu Key.
 - ⇒ A selection list appears.
- ▶ Select Save measuring window.
- ▶ Press OK.
 - ⇒ The change is saved.

5.14. Changing measurement program names

In the menu Selection meas. program the name of the measurement program can be changed.



- ▶ Press OK
 - ⇒ The menu Selection meas. Program appears
- ▶ Press F3.
 - ⇒ A window appears.
- ▶ Change the name of the measurement program to your needs
- ▶ Press OK.
 - ⇒ The changed name is displayed in the menu Selection meas. program

6 Preparing measurement

6.1. Ensure power supply

The analyser can be used with:

1. with the internal MRU battery (provided)
2. with the MRU battery charger (provided)

External equipment may only be connected while the analyser is switched off!



6.2. Automatic Auto-off function

The instrument is automatically switched off after 60 minutes. During a measurement or a battery charging cycle the auto off is deactivated.

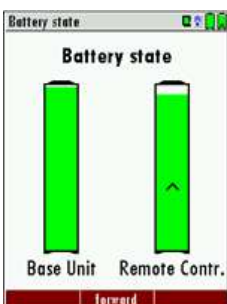

6.3. Measuring with grid power supply / Battery charging

Whenever you connect the base unit with external power supply (100..240 V / 50/ 60Hz) the battery of the base unit will be charged.

The battery of the Remote Control Unit (RCU) will be charged, if the RCU is in the charging frame of the mains connected base unit. The battery status screen will appear when the base unit is connected to the battery charger and the RCU is in its charging doc. This screen can also be manually opened with the menu button.

At the moment, if the battery is fully charged and the trickle charge mode begins an acoustic feedback will be played.

6.4. Battery charge condition

The battery symbols in the top right corner displays the current battery charge condition.

Approximately 15 minutes (depending on the analyser configuration) before the battery is drained, the battery symbol (base unit or RCU) will start to blink red (about once per second).

If the battery is almost drained and the analyser is not connected to the battery charger within one minute, then the analyser will switch off automatically to prevent deep discharge of the battery.

6.5. Operating temperature

If the analyser has been stored at low temperatures, it will require some time to equilibrate to the ambient temperature before being switched on. If it does not equilibrate, condensation will occur inside the analyser!

If the temperature is out of its operation range you will see the following messages on the display.

☞ See also Chapter 11.1 Technical data, Page 80.



ATTENTION

Once one of these messages appears you will not be able to use the analyser, the zeroing doesn't start until it has reached the specified operation temperature.

6.6. Controlling Condensate separator (water trap)

⚠ CAUTION



Acid from the condensate

ACID burns may result from weakly acidic liquids from the condensate.

- ▶ If you come into contact with acid, wash the area immediately using a lot of water.

- ▶ Control the condensate separator before and after each measurement
- ▶ Check that the condensate separator is empty.
- ▶ Check the star filter.
 - ⇒ Star filter white = ready for use
 - ⇒ Star filter dark = renew

When switching off, a warning message is displayed:

Base units with optional gas cooler require a frequent check of the pleated filter as well as the emptying of the condensate separator

6.7. Connections and tightness

Check all plug connections for correct fitting.

Check all hoses, hose connections, condensate containers (from the probe tip to the gas connection on the analyser) for tightness.

The analyser has a built-in automatic test to check the tightness of the gas paths.

☞ See also chapter 9.5 Performing leak test, Page 76.

6.8. Automatic zero-point setting



NOTE

The probe must not be in the exhaust gas during the zeroing

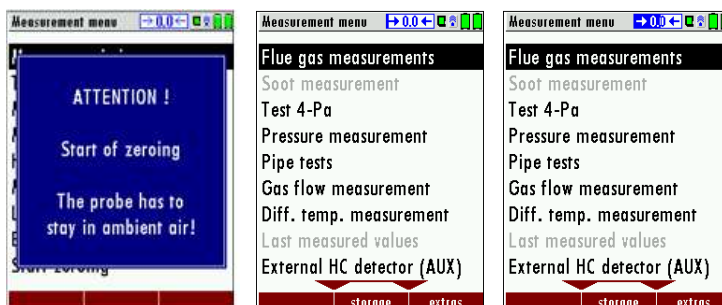

▶ Press the power

button on the base unit.

- ⇒ The analyser performs a zero point measurement automatically.
- ⇒ During zero point measurement, the -> 0.0 <- symbol flashes in the upper right corner of the display.
- ⇒ After zeroing is completed, the self diagnostics follows (Leak proof test, sensor test, flow control and battery status).
- ⇒ The unit will display any error (for example defect sensor) that is detected during the self-test. With the ESC button you can delete any displayed error messages and then reach the measuring menu

Repeating the zeroing

The zeroing can be repeated at any time as long as the probe is not inside the stack. In the main menu you select "Zeroing", and after the displayed message press the OK key.

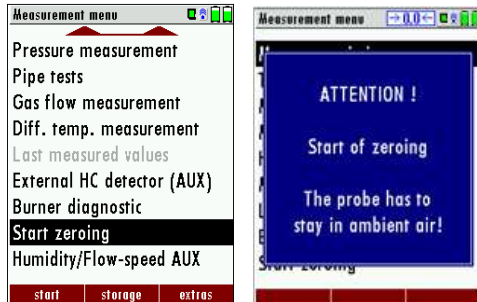

6.9. Zeroing with the 3-gas-NDIR bench

The zeroing of the 3-gas NDIR bench takes typically 7 to 10 minutes and maximal 18 minutes. After, this zeroing the measuring values are not stable for a longer time yet and will be displayed at first orange coloured. Nevertheless, a short time measurement is possible, but only the other (not orange coloured) values are correct according the specifications.

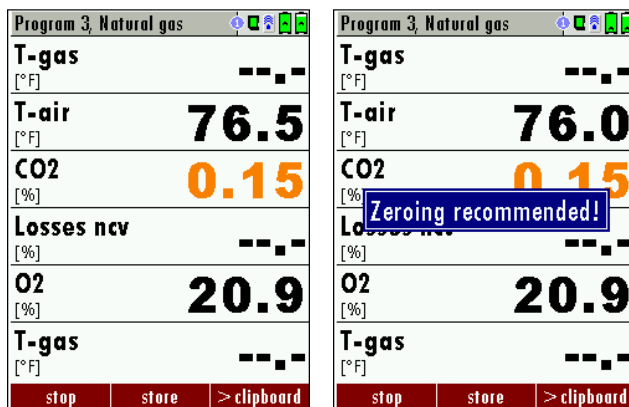

Aprox. 30 minutes after the first zeroing the analyser will display every 8 seconds „Zeroing recommended“. After the accomplishment of this second zeroing the colour of the displayed measuring values will be switch from orange to black and the measuring precision of the 3-gas NDIR bench is now correct.

7 Performing measurement

In the basic configuration, each analyser has the complete functionality you need for gas measurement.

The process of gas measurement is described below.

The description of other optionally available measuring programs can be found in the appendix or on separate supplementary sheets.



NOTE

When using the optional soot probe make sure that no soot test paper is inserted in your probe handle when performing a flue gas measurement.

7.1. Selecting the measuring program

⚠ DANGER



Rick due to toxic gases

There is a risk of poisoning.

Noxious gases are sucked in by the measuring device and released into the ambient air.

- ▶ Only use the measuring device in well ventilated spaces.

NOTE

Wrong measuring results



The extracted flue gas must be able to evacuate the analyser without obstruction.

- ▶ The exhaust outlet at the rear of the analyser may never be covered during a measurement, never operate the analyser in a transport case.

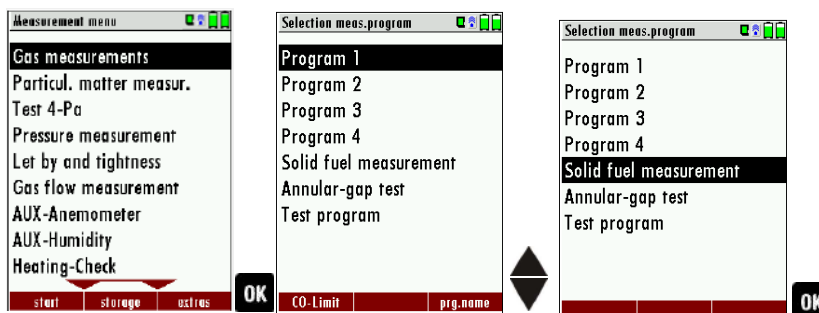

- ▶ Go to the Measurement menu.
- ▶ Press OK.
 - ⇒ The menu Selection meas. program appears.
- ▶ Select the desired measurement program.
- ▶ If necessary, change the CO limit.
 - ☞ See also Chapter Setting CO limit value, Page 34.
- ▶ Change the measuring program name if necessary.
 - ☞ See also Chapter 5.14 Changing measurement program names, Page 39.
- ▶ Press OK.
 - ⇒ The menu Fuel type selection appears.
- ▶ Select the desired fuel.
- ▶ If necessary, add fuels from the fuel type list to the menu Fuel type selection.
 - ☞ See also Chapter Adding fuels to Fuel type selection, Page 35.
- ▶ Press OK.
 - ⇒ The measurement is started.

NOTE

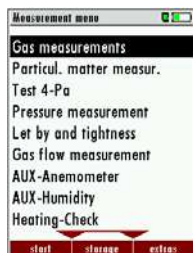

You can start a measurement with the previously set measurement parameters directly from the Measurement menu.

- ▶ Press F1.
- ⇒ The measurement is started.

7.2. Core flow search

The core flow search will help you to find the optimal measurement point in the stack. The core flow can be identified by the maximum flue gas temperature.

In high reaction time the analyser displays the trend of the flue gas temperature. Insert the probe pipe slowly into the stack and position your probe tube when you have reached the maximum flue gas temperature that is displayed.

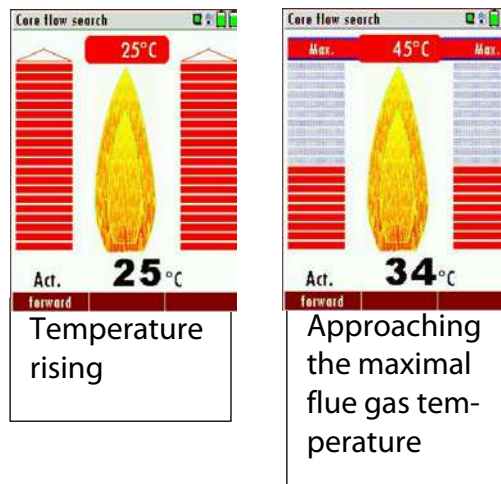

Positioning the probe in the core flow

Insert the probe pipe slowly into the stack and position your probe pipe when you have reached the maximum flue gas temperature that is displayed (see temperature maximum value on the display – in this case 34°C). Maximum temperature has been reached when the arrows (left picture) disappear, max. (right picture) appears in place of the arrow, and the beeper signal stops. Moving away from the max. temperature will result in the bars moving away from the max. temperature (1 bar is equivalent to 1°C). Once the right core flow has been achieved, the probe is fixed with the probe cone screw.

7.3. Measured value display

After the core flow search you will see the measurement values on the display. Measurement values can be organized on three pages, each page displaying 6 measurement values.

☞ See also chapter 5.12 Defining measurement window, Page 37.

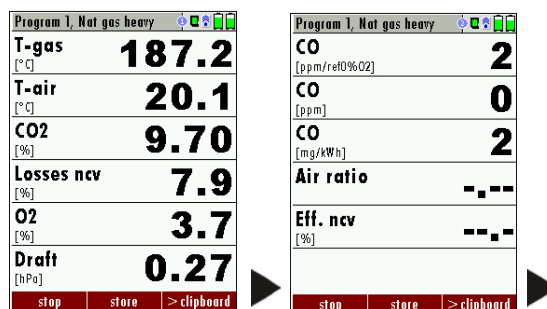

There are direct measured values available such as Oxygen and Temperature as well as calculated values such as dew point, efficiency and CO₂. You will also find the same measurement value in different calculated values such as CO in ppm or CO in mg/kWh.

Values that cannot be displayed are indicated with dashes. Possible reasons for value not being displayed are:

- Electro chemical sensor was detected as defective during zeroing.
- External temperature sensors are not connected.

The measurement value T-Gas is usually read at the connector "T-Gas/AUX" (depending on configuration) or if not available from the connector "T1".

☞ See also Chapter 6 Preparing measurement, Page 40.

There are three measurement windows available, with the arrow keys left and right moving between them.

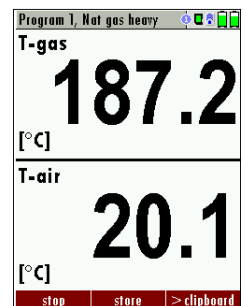

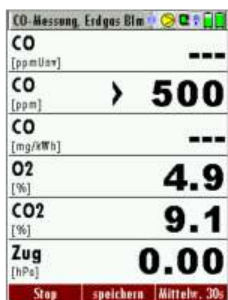

7.4. CO purging (optional)

If the CO ppm limit is reached the analyser will start the CO purging pump to protect the CO sensor from getting saturated with CO. Other values will not be affected while the CO sensor is being purged.

If the CO ppm limit is reached the CO purging symbol will be displayed.

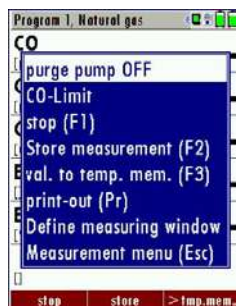

The CO sensor will be purged. The displaying of a measuring value does not occur any more.

The „>“symbol shows, that the COlimit value is exceeded.

The purging does not stop automatically; it must be turned off by the user.

Press the “Folder” menu key and select “purge pump off” to cancel the CO purging function as soon as the CO value fall below the CO limit.

7.5. CO/H2 and CO high (optional)

If that exceeds CO the CO threshold, then to CO high, the measured value is red indicated - also the calculated values - is switched.

The CO value exceeds 10.000 ppm to % is in such a way switched (example 1.00%).

If the CO value sinks below the CO threshold, then the red CO value becomes again black

Starting from this moment the purge pump can be switched off over the menu key.

7.6. Specific measurement applications

30 sec. average value calculation according 1. BImSchV_2010

This function is available if you have received your unit with German configuration.

Abgasmessung, Erdgas BImSchV		Abgasmessung, Erdgas BImSchV		Average value above 30s	
T-gas [°C]	187.2	T-gas [°C]	187.2	T-gas [°C]	187.2
T-air [°C]	20.1	T-air [°C]	20.1	T-air [°C]	20.1
CO2 [%]	9.70	CO2 [%]	9.70	CO2 [%]	9.70
Losses ncv [%]	7.9	Losses ncv [%]	7.9	Losses ncv [%]	7.9
O2 [%]	3.7	O2 [%]	3.7	O2 [%]	3.7
Draft [hPa]	0.27	Draft [hPa]	0.27	Draft [hPa]	0.27
stop store Avg.w. 30s F3		stop store 19 Sek.		start store > clipboard	

► Press F3 in the measuring window.

- ⇒ The average value calculation is started.
- ⇒ In the right bottom corner of the display the countdown from 30 to 0 will be displayed
- ⇒ Once the countdown is completed the measurement will stop automatically.
- ⇒ The per 30 seconds determined Loss Values will be market in the measurement print out

The countdown can be stopped at any time using the F1 button (the measurement will be stopped as well).

Annular-gap measurement program

This program is used to find leaks in the double walled exhaust duct of condensing boilers. It is done by measuring the O₂ value in the combustion air.

Measurement menu	Selection meas.program
Flue gas measurements	Program 1
Soot measurement	Program 2
Test 4-Pa	Program 3
Pressure measurement	Program 4
Pipe tests	Solid fuel measurement
Gas flow measurement	Annular-gap test
Diff. temp. measurement	Test program
Last measured values	
External HC detector (AUX)	
start storage extras	

	Select Annular gap measurement
F1	Start Annular gap measurement
F3	Draft measurement and annular-gap temperature measurement is determined on the 2nd measuring step with the standard probe
F2	Save measured values
ESC	Back to the measurement menu without saving

For this measurement MRU offers an annular gap probe (Part no. 56352) which can be connected to the condensate separator of the analyser. Optional you can connect the annular gap probe with an adaptor (Part No. 11652) to the tip of the probe pipe.

Test program

This test program is made for testing facilities that will test these analysers with test gases and don't need to make any modifications. In this program you will only see measured values and no calculated values at all.

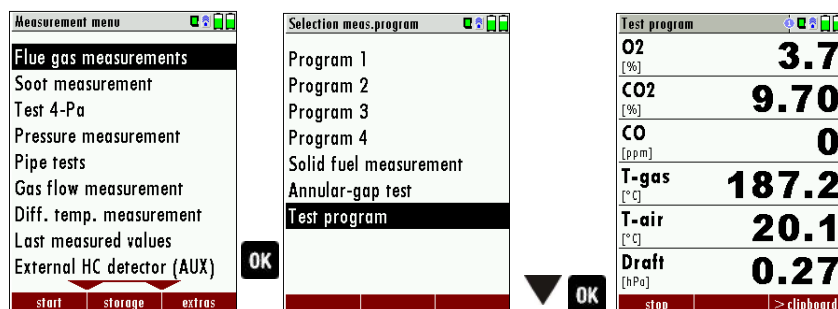

- ▶ Go to the Measurement menu.
- ▶ Select Flue gas measurements.
- ▶ Press OK.
 - ⇒ The menu Selection meas. program appears.
- ▶ Select Test program
- ▶ Press OK.
 - ⇒ The menu Test program appears.

Performing Ambient CO Test

In some countries the measuring program CO environment is demanded. The objective of this measuring program is the proof of CO concentration in the environment of the measuring point. In the case of the country setting in the main menu the menu option is indicated „CO ambient“

- ▶ Perform a zero point measurement outside of the environment of the measuring location before you perform a CO Ambient Test.
 - ⇒ After zeroing, you can perform a CO ambient measurement.
 - ☞ See also chapter Repeating the zeroing, Page 43.

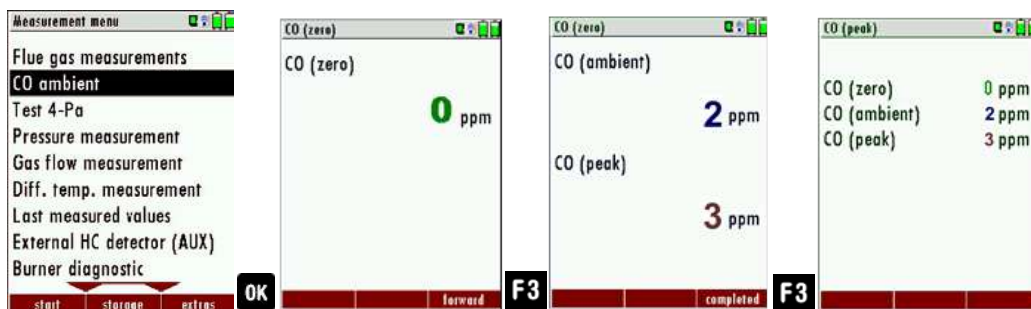

- ▶ Select CO ambient
 - ⇒ The menu CO (zero) appears. The current CO value (zeroing) as a check is indicated. (This value must be approx. 0 ppm!)
- ▶ Go to the measuring point.
- ▶ Press F3.
 - ⇒ The menu CO (zero) appears.
 - ⇒ The CO Ambient test is performed.
 - ⇒ The current CO (ambient) and CO (peak) values will be indicated.
- ▶ Press F3.
 - ⇒ The measurement is finished.
 - ⇒ The CO (zero) value, CO (ambient) value and the CO (peak) value are displayed.

7.7. Temporary buffer

The analyser gives the possibility to set the momentary values into a temporary buffer during effecting and continuing the measurement.

Later on, the values can be brought back from the temporary buffer to the measuring window in order to print them out or / and to save them.

Store measured values in the buffer

During an actual measurement you can set the actual values into the clipboard.

Operation:

- the function „val. to clipboard“ of the menu (accessible about the menu button)

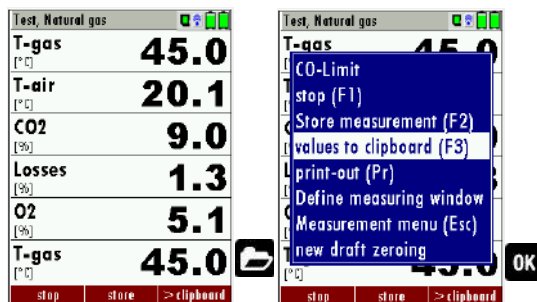

► Start a measurement.

☞ See also chapter 7.1 Selecting the measuring program, Page 44. .

► Press the Menu Menu Key.

⇒ A selection list appears.

► Select values to clipboard.

⇒ The measured values are stored in the temporary buffer.

If offered, you can store measured values directly from the function key bar in the temporary buffer.



Overwrite measured values in buffer

When the measurement is stopped, you can overwrite the displayed measured values with the measured values stored in the temporary buffer.

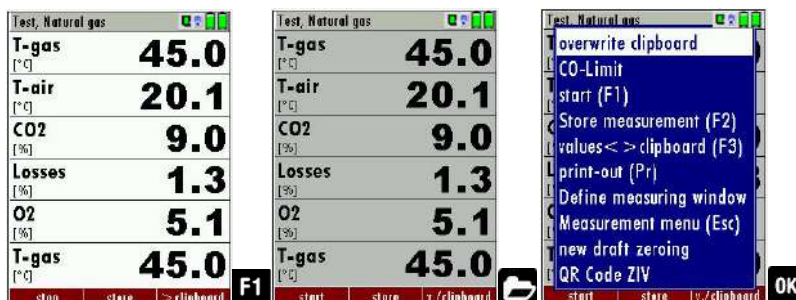

- ▶ Press F1.
 - ⇒ The measurement is stopped
 - ⇒ The measured value window is highlighted in grey.
- ▶ Press the Menu Key.
 - ⇒ A selection list appears.
- ▶ Select overwrite clipboard.
- ▶ Press OK

Now you can change the current values and the values of the temporary buffer with the key F3. This change of the actual values with the values of the temporary buffer memory can be executed several times one after the other

Now it is possible to print and save as usual one of both measurements.

If offered, you can overwrite measured values directly from the function key bar in the temporary buffer.



'> clipboard'	current values to the empty clipboard
'> clipbrd >'	replace (overwrite) clipboard values with current values
'v./clipboard'	after stopping the measurement via F1 key (stop): swap indicated values with those in the clipboard

7.8. Storing measured values

If in the function key bar "store" is indicated, you can store with the accompanying function key F2 or F3 the measurement in the data memory.

☞ See also chapter 8Data Storage,S.59.

Entering T-boiler, Soot No. and Derivative

The analyser has no soot measurement, but you can insert, save and print soot data.

- ▶ Before using this function, it must be switched on in the Measurement settings.

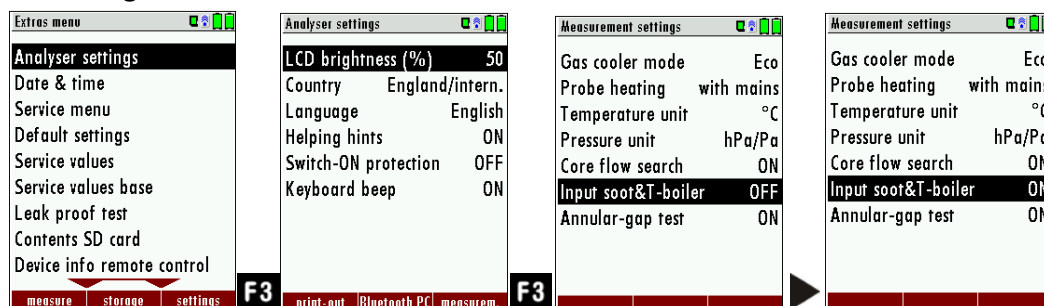

- ▶ Go to the Extras menu.
- ▶ Press F3.
 - ⇒ The menu Analyser settings appears.
- ▶ Press F3.
 - ⇒ The menu Measurement settings appears.
- ▶ Switch Soot&T-boiler ON.
- ▶ After a successful measurement, you can enter the externally determined measured values.



NOTE

The input possibility of soot values and derivate is given only with the fuel oil.

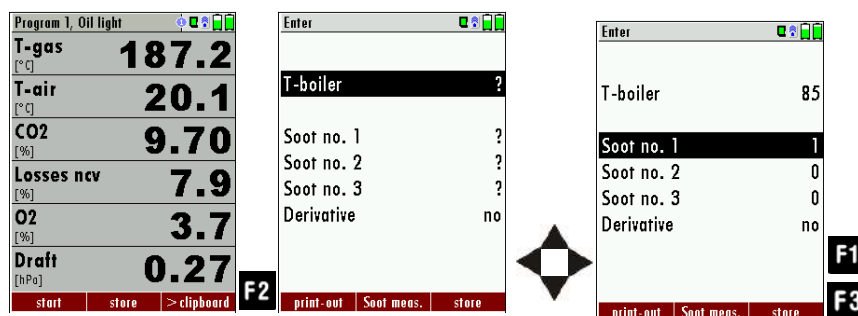

- ▶ Press F2.
 - ⇒ The menu Enter appears.
- ▶ Enter the determined values for T-boiler, Soot no. 1, Soot no. 2, Soot no 3 and Derivative.
- ▶ Press F1 to make a printout.
- ▶ Press F2 to store the measurement.

7.9. Printing measurement values

Measurement results can be printed using the printer button. Printer line feed is activated when pressing the printer button outside of a measuring screen. All measurement values which are activated in the measurement screen will be printed (values which are selected more than once will only be printed once).



To change the printer paper, you pull out the little plastic recessed grip (2) which is mounted on the transparent printer cover (1). Insert the new printer roll and let the end of the paper stick out of the printer (+/- half inch). Close the printer cover (marking 3) using only with light pressure. Paper feed is activated using the printer button (when not in measuring window).

7.10. Terminate measurement

A current emission measurement can be stopped at any time with the F1 key. The display will change its colour and the measurement will be frozen. At the time you stop the measurement all measured values are still available and can be viewed at a later time.

Return to the measurement menu by pressing the ESC key.

☞ See also chapter 7.11 Last measurement values, Page 55.

Return to the measurement menu by pressing the ESC key.

7.11. Last measurement values

The analyser offers the possibility to continue working with the last measured values after the end of a measurement.

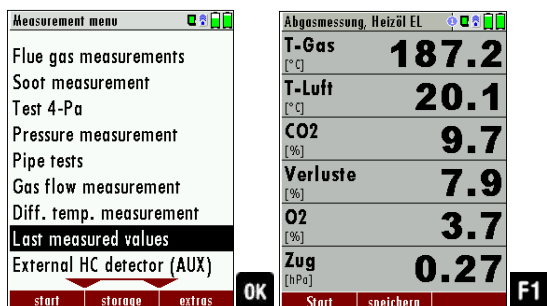

▶ Go to the Measurement menu.

▶ Select Last measured values.

▶ Press OK.

⇒ The measured value window with the last measured values appears.

▶ Press F1. The measurement is continued.

7.12. Pressure measurement

Pressure (4 values) is measured and saved to the selected measurement name. The actual measured value is displayed in the middle of the display. The 4 measurement names can be changed as desired.

Rearrangement of the differential pressure sensors:

To be able to use the pressure sensors in the RCU (only Comfort Model) as well as the pressure sensors in the base unit a selection will take place using the arrow keys:

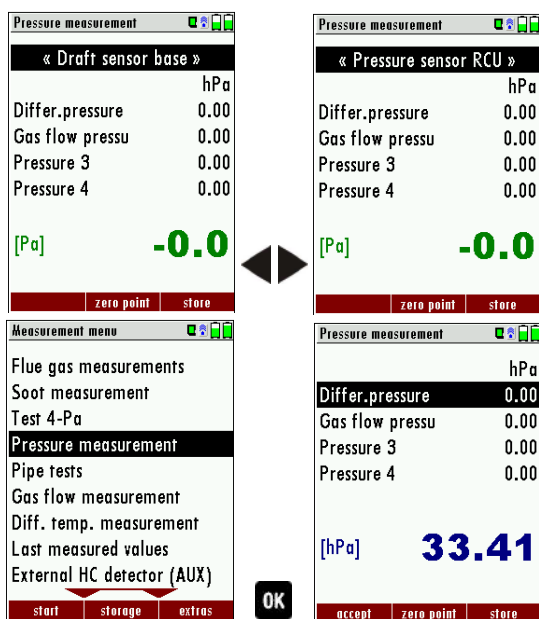

	Select the measurement name 1-4
F1	Save the measured value to one of the measurement name
F2	Zeroing the pressure sensor
F3	Change the name of the measurement category
ESC	Return to the measurement menu



NOTE

The pressure of the remote control (RCU) can also displayed in the flue gas measurement.

7.13. Differential temperature measurement

The RCU (only comfort version) can display two temperature values in the menu Differential Temperature if two temperature sensors are connected to T1 and T2. The RCU will also calculate and display the differential temperature.

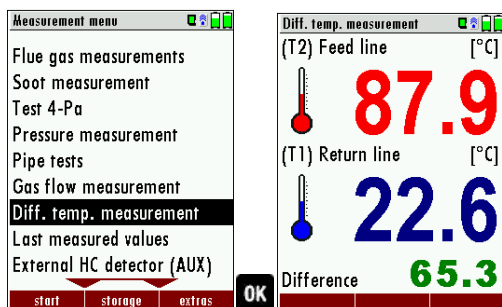

- ▶ Go to the Measurement menu.
- ▶ Select Diff. Temp. measurement.
- ▶ Press OK.
 - ⇒ The menu Diff. temp. measurement appears.
 - ⇒ The temperatures T1, T2 and the difference are displayed.



NOTE

The accuracy of the difference temperature measurement is guaranteed only on use of the MRU temperature sensors.

7.14. Performing measurements on CHP units (option)

With the CHP option, you can carry out flue gas measurements on combined heat and power units. If this option is installed in the analyser there is an accessible Purafil filter on the front of the analyser.

Due to high NOx values in CHP measurements, an additional Purafil filter is necessary to protect the measuring device.





ATTENTION

Check the Purafil filter by visual inspection before each measurement. Replace the Purafil filter if necessary to protect the meter from high NOx levels.



NOTE

Please note that depending on the options installed certain representations of menu items / measurements in this manual and the actual representation on your analyser may differ

8 Data Storage

8.1. Organizing data storage

Basis of the data memory of the analyser is a set of sites stored in the device. Every site exists of a unique site number and 8 freely usable text lines which can have, e.g., the address, customer name etc.

The device can store up to 4000 different sites.

Sites can be created in the device and be changed, or could be imported from a PC program. Attention: sites created in the device and site data changed in the device will not be updated towards the PC. The device does only transmit to the PC the measurement values, but no information about site data.

Measurements are stored by assigning them to a site. Measurements can be, on this occasion, singles flue gas measurements or other measuring programmes available in the device.

8.2. Calling up information about data storage

In the menu item "storage" you select „memory info“ get information about the actual memory volume. The part of free memory, the total number of the stored sites and the number of the measurements stored all together, split in the kind of the measurement is listed.

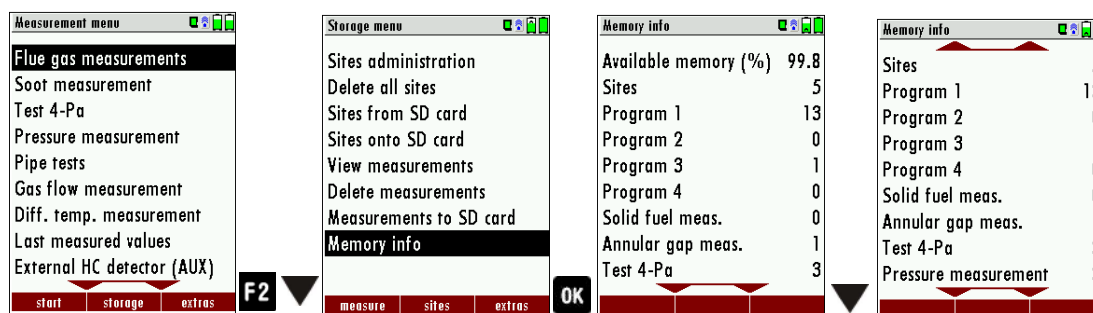

► Press F2

⇒ The Storage menu appears.

► Select Memory info.

⇒ The menu Memory info appears.

⇒ Information about the data storage is listed.



8.3. Site administration

In the menu item "Sites administration" you are able

- view all data of the stored sites
- create new sites
- change date of existing sites
- delete sites

In the device new created sites and changes in the data of a site will not transmit to the PC back.

Create new site



- ▶ Go to the Storage menu.
- ▶ Press F2.
 - ⇒ The menu Sites administration appears.
- ▶ Press F1.
 - ⇒ The menu Modify site appears.
- ▶ Press F1 to assign manually a site number to the site.
- ▶ Press F2 to assign automatically a site number to the site.
 - ⇒ The site is assigned a site number.
- ▶ Select the free text lines that you want to edit.
- ▶ Press F1.
 - ⇒ A window appears.
- ▶ Enter the desired content.
- ▶ If necessary, select further free text lines and fill them with content.
- ▶ Press F3.
 - ⇒ The site is stored.

View sites



- ▶ Go to the Storage menu.
- ▶ Select Site administration.
 - ⇒ The menu Sites administration appears.
 - ⇒ Each stored site is displayed on a page with the coloured site number and eight additional free text lines.
- ▶ If necessary, scroll through the sites until you have found the desired site.

NOTE



You also have the possibility to search for sites by set-ting a search mask.

☞ See also chapter Searching site, Page 61.

Searching site

You have the possibility to enter certain parameters in order to search for particular sites. In the following example we will search for the site that is assigned to John Example.

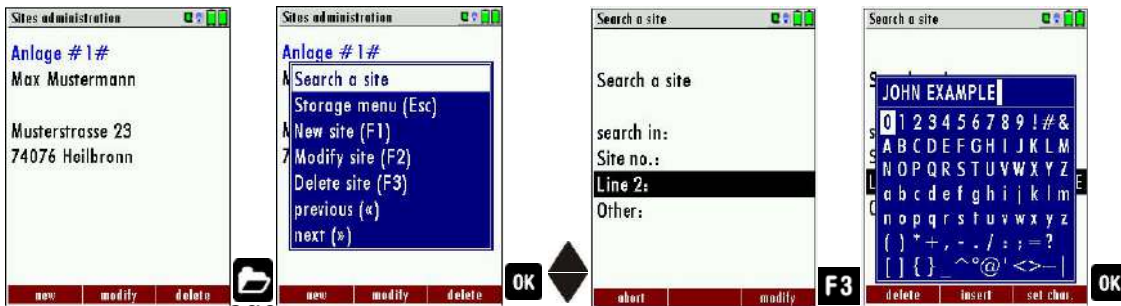

- ▶ Go to the storage menu.
- ▶ Press the Menu Key.
 - ⇒ A selection list appears.
- ▶ Select search a site.
- ▶ Press OK.
 - ⇒ The menu Search a site appears.
 - ⇒ You can choose to filter by Site number, by content in Line 2 or for the rest of the other text lines.

- ▶ Select a line in which you want to search for content.
In this example, the search is performed in line 2.
- ▶ Press F3.
 - ⇒ A window appears.
- ▶ Enter the desired search term
In this example the search term is John Example.
- ▶ Press OK.
 - ⇒ The menu Search a site appears.
 - ⇒ The search term appears in the selected line.

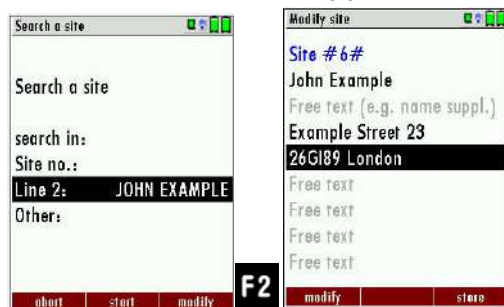

- ▶ Press F2.
 - ⇒ The site that is assigned to John Example is displayed. If several sites were found, the total number is displayed in the header and you can scroll through these found sites.

Changing sites



- ▶ Go to the Storage menu.
- ▶ Select Sites administration
- ▶ Press F2.
 - ⇒ The menu Sites administration appears.
- ▶ Select the site that you want to change
- ▶ Press F2.
 - ⇒ A bar appears.
- ▶ Select the free text lines that you want to change.
- ▶ Press F1.
 - ⇒ A window appears.
- ▶ Enter the desired changes.
- ▶ If necessary, select further free text lines and change the corresponding free text lines
- ▶ Press F3.
 - ⇒ The changes are stored.

Deleting sites

You can delete sites individually or delete all sites simultaneously

Deleting sites individually

You can delete sites individually or delete all sites simultaneously



- ▶ Go to the Storage menu.
- ▶ Select Sites administration.
- ▶ Press F2.
 - ⇒ The menu Sites administration appears.
- ▶ Select the site you want to delete.
- ▶ Press F3.
 - ⇒ A message appears.
- ▶ Select continue to delete the site
- ▶ Select abort to retain the site.
- ▶ Press OK.
 - ⇒ Depending on the selection, the site is deleted or retained

Deleting all sites

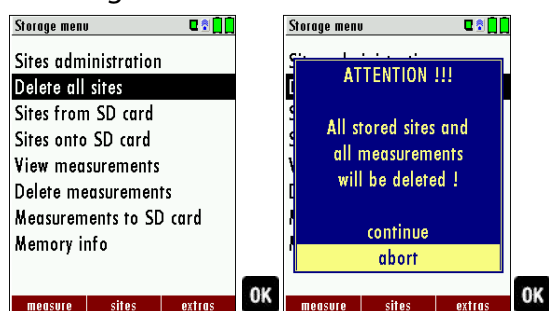

- ▶ Go to the Storage menu
- ▶ Select Delete all sites.
- ▶ Press OK.
 - ⇒ A message appears.
- ▶ Select continue to delete all sites.
- ▶ Select abort to retain all sites.
- ▶ Press OK.
 - ⇒ Depending on the selection, the site is deleted or retained

Data transfer using SD card (option)

The data exchange format is CSV. A character-separated values (CSV) file is a simple text format for a database table. Each record in the table is one line of the text file. Each field value of a record is separated from the next by a character. NOVApplus Combustion Analysers uses a semi-colon ';' as value

separator (other implementations use sometimes a comma). Implementations of CSV can often handle field values with embedded line breaks or separator characters by using quotation marks or escape sequences. CSV is a simple file format that is widely supported, so it is often used to move tabular data between different computer programs, for example Microsoft Excel™ or Access™, that support the format. Also, other computer programs offer this type of interface because it is widely spread and easy to use.

The following functions are available from Software Version 1.11 and higher:

- 1.Importing sites
- 2.Exporting sites
- 3.Exporting combustion measurements
- 4.Exporting differential pressure measurements

Importing sites

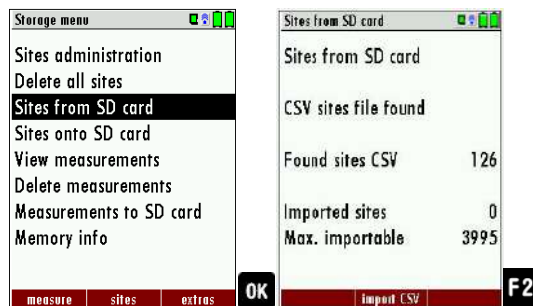

- ▶ Go to the Storage menu.
- ▶ Select Sites from SD card.
 - ⇒ The Menu sites from SD card appears.
- ▶ Press F2, to select Import CSV.

With this function you can Import Sites which have been created on a computer or another Analyser.

The File name must have the name "anlagen.csv" (anlagen = German for sites) . The file has no column heading that means that the first line already has user data. Each line has a minimum of 9 columns (with 8 semi-colons) and the first field in the line will be the site number. All data will be imported as long a site number is available. Per field a maximum of 24 characters will be imported, too long words will be cut off.

Example file with 8 valid sites (4 with 9 lines and 4 with less lines):

```
A1-Z1;A1-Z2;A1-Z3;A1-Z4;A1-Z5;A1-Z6;A1-Z7;A1-Z8;A1-Z9
A2-Z1;A2-Z2;A2-Z3;A2-Z4;A2-Z5;A2-Z6;A2-Z7;A2-Z8;A2-Z9
A3-Z1;A3-Z2;A3-Z3;A3-Z4;A3-Z5;A3-Z6;A3-Z7;A3-Z8;A3-Z9
A4-Z1;A4-Z2;A4-Z3;A4-Z4;A4-Z5;A4-Z6;A4-Z7;A4-Z8;A4-Z9
A5-Z1;A5-Z2;A5-Z3;A5-Z4;;;;;
A6-Z1;A6-Z2;;A6-Z4;;;;;
A7-Z1;;;A7-Z4;;;;;
A8-Z1;;;;;;;
```

Example file with 2 invalid sites (1 with not enough fields and 1 with missing site number):

```
A1-Z1;A1-Z2
;A1-Z2;A1-Z3;A1-Z4;A1-Z5;A1-Z6;A1-Z7;A1-Z8;A1-Z9
```

NOTE



While importing data from the SD Card to the analyser there is no check for double site numbers (Line 1), neither inside of the file that is imported nor between the file and the sites already inside the analyser. The analyser can easily handle double site numbers but you could face problems with double site numbers when exporting them again to a computer program (see also Export of Measurements).

However, the analyser marks the files that have been imported successfully. If you try to import a file with the same analyser that is already in the analyser you will get a red information screen.

Exporting sites

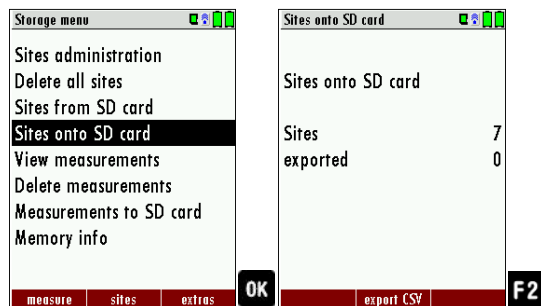

- ▶ Go to the Storage menu.
- ▶ Select Sites onto SD card.
- ▶ Press OK.
 - ⇒ The menu Sites onto SD card appears.
- ▶ Press F2.
 - ⇒ The sites are exported.

This function can be used for an analyser back up or if you wish to supply the analyser information to a computer program or another analyser. This is very handy if you have made some modifications inside the analyser (site) for example if you have modified the phone number of a customer and this modification needs to be updated in the computer software, or if a second analyser needs to have the same site information.

The File format is the same as described above „Import of Sites“.

Only the file name is different, the file name will be ‚ANLxxxx.csv‘, in which the xxxx are continuing 5-digit numbers with leading zeros. If the file must be imported into another analyser, the file must first be renamed into „anla-gen.csv“.

Exporting combustion measurements

This function is used to export the measurements from the analyser to a computer program



NOTE

This function is not suitable for back up or for the transfer to another analyser because the exported file can't be imported again!

The created file has the name ‚EMIxxxx.csv‘, in which the xxxx are continuing 5-digit numbers with leading zeros.

The created file has a column header with the following information: Site number, Date/Time, Measuring program name, Fuel type, CO2max, O2reference, and all measured values that the analyser can measure as well as the soot numbers, Derivate and T-Boiler.

Example:

	A	B	C	D	E	F	G	H	I	J	K
1	Site no.	Date & time	meas.progra	fuel type	CO2max [%]	O2ref [%]	T-gas [°F]	T-air [°F]	Dewpoint [°F]	O2 [%]	CO2 [%]
2	BOILER	THU 30.09.2012	Program 1	Natural gas	11.7	3.0	---	73.5	---	21.0	---
3	BOILER	THU 30.09.2012	Program 1	Natural gas	11.7	3.0	---	73.0	---	21.0	---
4	BOILER	THU 30.09.2012	Program 1	Natural gas	11.7	3.0	---	73.0	---	21.0	---
5	BOILER	THU 30.09.2012	Program 1	Natural gas	11.7	3.0	---	72.5	---	21.0	---
6	BOILER	FRI 01.10.2012	Program 1	Natural gas	11.7	3.0	---	72.5	---	21.0	---
7	A FURNACE	TUE 05.10.2012	Program 1	Natural gas	11.7	3.0	81.0	---	113.0	11.7	5.2
8	A FURNACE	TUE 05.10.2012	Program 1	Natural gas	11.7	3.0	81.0	---	113.0	11.7	5.2
9	A FURNACE	TUE 05.10.2012	Program 1	Natural gas	11.7	3.0	82.5	---	112.5	11.7	5.1
10	A FURNACE	TUE 12.10.2012	Program 1	Natural gas	11.7	3.0	84.5	---	132.5	2.7	10.2

Exporting differential pressure measurements

The same function as Export of combustion tests only the file name is different. The created file has the file name "DDMxxxx.csv", in which the xxxx are continuing 5-digit numbers with leading zeros.

The created file has a column header with the following information: Site number, Date/Time, as well as 4 saved pressure measurements.

8.4. Measurements in Data storage

Viewing Measurements

In the menu item „View measurements“ you can inspect the stored measurements. After selection of this item you receive first an overview of the number of the stored measurements according to measuring type.

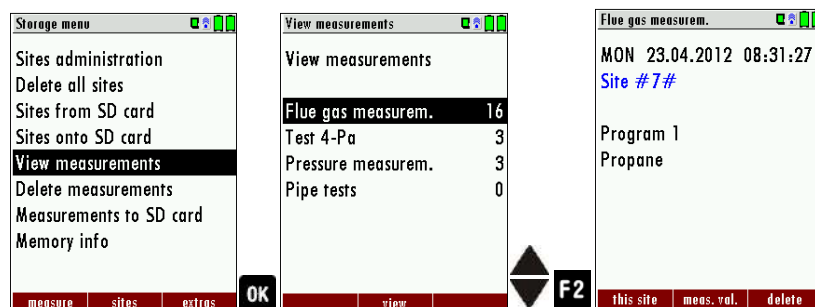

- ▶ Go to the Storage menu.
- ▶ Select View measurements.
- ▶ Press OK
 - ⇒ The menu View measurements appears.
 - ⇒ An overview of the number of stored measurements according to the measurement type appears.
- ▶ Select the desired measurement type.
- ▶ Press F2.
 - ⇒ Then you receive first a page with context information to the stored measurement. Scroll with the arrow keys by the context information of the stored measurements.
- ▶ With F2 = "measured value" are displayed the measured data of the stored measurement in detail, available in 3 measuring value pages, as they are defined in the measuring value window.
- ▶ With ESC you return to the context information of the measurement.

You have the possibility to display only those data that are assigned to a single site:

- either F1 = „this site“ , while a measurement of the desired site is displayed. With F1 = „all sites“ you cancel this filter again.
- or while you select with the menu key the function "search a site" and execute, as described in the chapter site administration.

Deleting measurements

You are able to

- delete single measurements, while they are displayed – press the key F3 = "delete" .
- or delete all measurements of a measuring type.

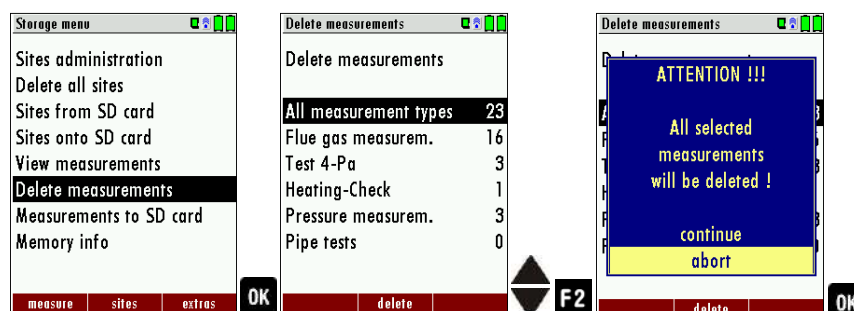

- ▶ Go to the Storage menu.
- ▶ Select Delete measurements.
 - ⇒ The menu Delete measurements appears.
- ▶ Select which measurement type you want to delete.
- ▶ Press F2.
 - ⇒ A message appears.
 - ⇒ Select continue to delete all measurements.
 - ⇒ Select abort to retain all measurements.
- ▶ Press OK.
 - ⇒ Depending on the selection, the measurement data are deleted or retained.

Transferring measurements to SD-Card (Option)

The analyser offers the possibility to export all stored measurements to a SD card

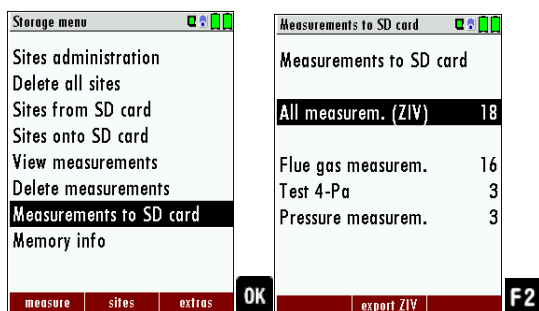

- ▶ Go to the Storage menu.
- ▶ Select Measurements to SD card.
- ▶ Press OK.
- ▶ Select the desired measurement type.
- ▶ Press F2.

⇒ The selected measurement card type is transferred to the SD card.

By confirming with the F2 key the data transmission / export on the SD card is started.

During the data export the display reads „please wait“. A write error to SD card is reported by the instrument. Make sure that the SD card is not write protected.

The data are stored as a csv-file (e.g., EMI01032.csv) on the SD card. The file-name exists of a sequential number which fixes the device.

This file is editable on your Notebook/PC with a program like e.g. Microsoft® EXCEL or OpenOffice® Calc.

With possible problems with the using of your computer programs please read your software documentations or ask your software dealer.

8.5. Data transfer to the PC (Sweeping district management programs)

What is necessary for a data transfer to a sweeping district management program?

The data memory can be transferred to a PC via USB. The MRU-ZIV module is required for this.

Which requirements are necessary on the PC?

The Analyser must be registered on the PC as a HID conform device.

What does the MRU-ZIV module?

The MRU-ZIV module is only used for data exchange. Via the USB cable the stored measurements can be read in the analyser. It is also possible to transfer site data (site no., address, etc.) to the analyser. The ZIV module transfers the stored measurements to a sweeping district management programme or receives the system data from the sweeping district management programme. The stored measurements can then be further used in the sweeping district management program.

How must the MRU-ZIV module be integrated into the sweeping district management program?

Please contact the developer of the program.

How do I have to install the MRU-ZIV module?

The software MRU-ZIV module can be found on the MRU product CD in the Software folder. During installation, the manual for the MRU-ZIV module is stored on your hard disk, which you can print out if necessary.

9 Extras / Adjustments

The analyser is delivered in a standard software configuration which should cover most needs. However, there are many ways to tailor the settings to your individual needs if required. The possibilities are highly flexible and individual adaptable.

Use the variable possibilities to adapt your analyser to your own needs and customize the measurement menu, the measurement window, the printer output and many other features. Usually this is something you will do once you receive the analyser, once you have adapted your analyser you will most probably don't make much changes in future, but you can whenever you need and want to do so.

After you have made any changes in the configuration, you should switch off the analyser to save all the changes that have been made. Next time that you start up the analyser, all changes will have been made.

9.1. User definable Logo print out

Overview:

The Logo file can be created out of a Bitmap using the program "NOVAPplusPrnLogoCreator.exe" which comes with the analyser CD. The generated file will be transferred from your computer to the analyser using the SD card (only once). Once transferred the Logo can either be printed above or below the customer address or you can choose not to print the logo at all.

Converting a Bitmap into a Logo file:



Use the enclosed Windows-Program "NOVAPplusPrnLogoCreator.exe" (MRU Product CD / Software / NOVAPplusPrnLogoCreator).

The Bitmap can have any colour depth bit ideal is a colour depth of 1-bit black-white. The horizontal resolution must have 384 pixels. If necessary the Bitmap can be adjusted using a picture editing program (not included on the CD).

The vertical resolution of the Bitmap must be a multiple of 24, where 24 is the minimum and the maximum is 480 pixels. If necessary the Bitmap can be adjusted using a picture editing program (not included on the CD).

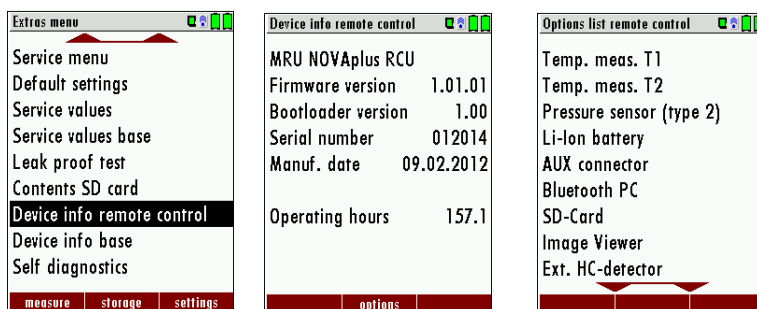

Transferring the Logo file per SD card to the analyser:

Copy the created file "lg_print.mru" onto the SD card (root).

Switch on the analyser then navigate to – Extras (F3) Analyser info RCU / options. Now insert the SD card into the SD card slot, the unit will conform the upload with a short beep and on the screen, you will see a short message – Logo installed.

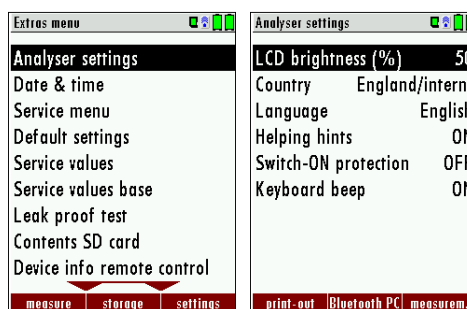

Printer Logo setting:

As soon as the Logo has been installed and the printer type is set on MRU, the Logo print will be available in the menu "extras / settings (print Logo).

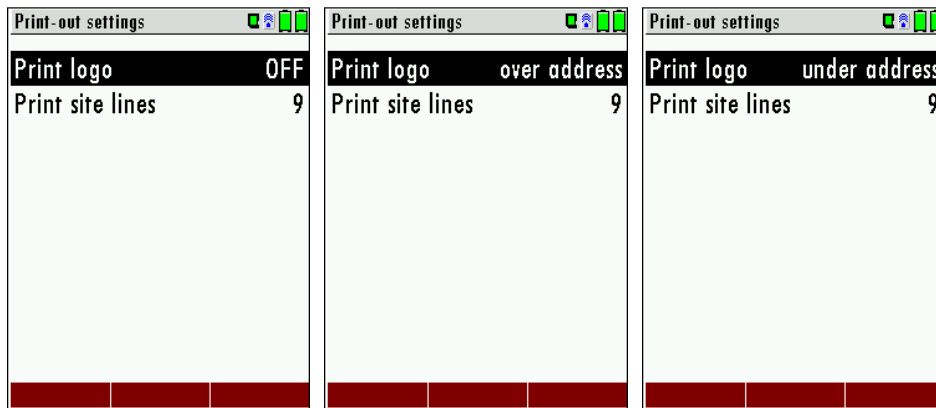

9.2. Service calibration menu

The Maintenance adjustment menu is secured with a Pin Code to protect it against unauthorized users.

If you enter a wrong pin code you will be exited into the “Extra Menu” again.

Please contact MRU GmbH if you need the Pin Code for your analyser.

Press the Enter key if you should have landed in this menu by accident and you will be exited into the “Extra Menu” again.

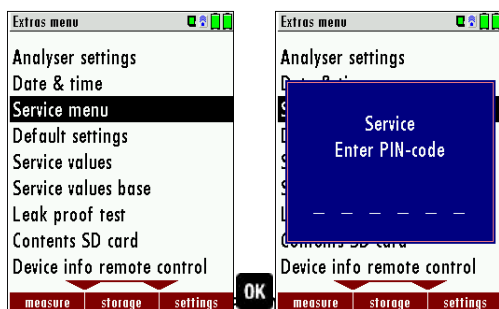

- ▶ Select Service menu.
- ▶ Press OK.
 - ⇒ A window for entering the PIN-code appears.
- ▶ Enter the PIN-Code.
 - ⇒ If you enter the PIN-code correctly, you will have access to the service menu
 - ⇒ If the PIN-code is entered incorrectly, you will be returned to the Extras menu.

9.3. Default settings

The analyser will be reset to original delivery settings.



NOTE

With the default setting, all individual settings are lost.

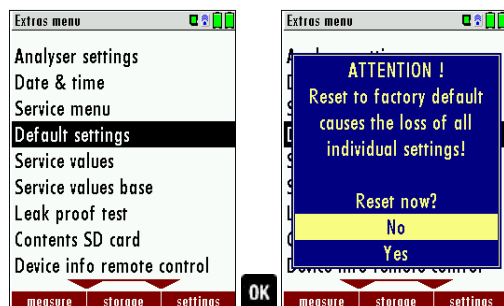

- ▶ Go to the Extras menu.
- ▶ Select Default settings.
- ▶ Press OK.
 - ⇒ A window appears.
- ▶ Select "No" to not reset the default settings.
- ▶ Select "Yes" to reset the analyser to default settings.
- ▶ Press OK.
 - ⇒ Depending on the selection, the analyser is reset to the default settings or not.

Be aware that your configurations will be deleted, such as:

CO-ppm limits
 Fuel type list activation
 Measurement window selection
 and others.

9.4. Service values RCU / Service values Base unit

Should your analyser display an error message after zeroing (for example: „O2-Sensor not OK"), then you can use the Service value menu to get detailed information about possible defects. In this menu you will see all service values of the sensors and also other parameters.

In case of a defect contact the MRU service department. The MRU service technician will ask you about these values or he will ask you to send them by fax or email.

Service values RCU:

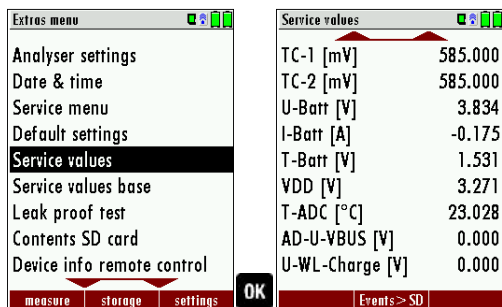

▲, ▼	Jump between the lines
F2	Export of service values to SD card
ESC	return

Service values base unit:

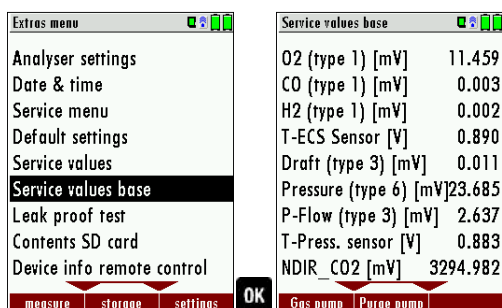

▲, ▼	Jump between the lines
F1	Function test gas pump (on / off -> only with service PIN code!)
F2	Function test purge pump (on / off -> only with service PIN code!)
ESC	return

9.5. Performing leak test

With the leak proof test, the system is checked by the device (incl. the condensate separator) up to the probe spike on undensity. The internal gas pump generates in addition a subpressure which is measured over the built-in draft sensor and is observed for a period of 10 seconds. Based on the decrease of pressure the leakiness of the system will be determined.

Operation:

- ▶ The leak proof test cap # 61382 (for probe tubes Ø 8 mm) must be put on the probe spike.



NOTE



With dirt and soot particles on the probe tube the test cap will not seal properly.

- ▶ The probe tip must be cleaned before you start this test!



- ▶ Go to the Extras menu.
- ▶ Select Leak proof test.
- ▶ Press OK.
 - ⇒ The menu Leak proof test appears.
- ▶ Ensure that the leak test cap is plugged in.
 - ⇒ Pressure is established.
 - ⇒ A 10-second test is running.
 - ⇒ A message appears whether the leak proof test was passed or not.
- ▶ Remove the proof test cap.

If of the leak proof test is not passed the probe must be checked including the hosing as well as the condensate separator.

If no undensity is ascertained in these external parts the analyser has to be checked in a service department (worldwide service departments see www.mru.eu).



9.6. Contents SD card

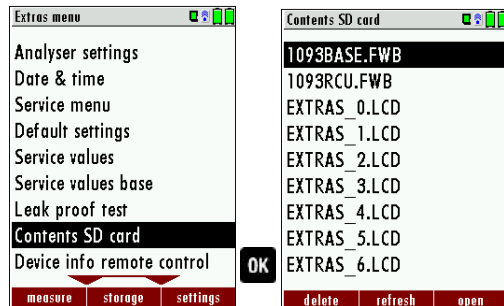

Extras menu.

- ▶ Go to the
- ▶ Select Contents SD card.
- ▶ Press OK.
 - ⇒ The menu Contents SD card appears.
 - ⇒ The files stored on the SD card are displayed.
- ▶ Select a file.
- ▶ If necessary, press F1 to delete the file.
- ▶ If necessary, press F2 to refresh the file.
- ▶ If necessary, press F3 to open the file.

9.7. Contents Analyser info

Here you will find information about the analyser and the installed options

Options list remote control

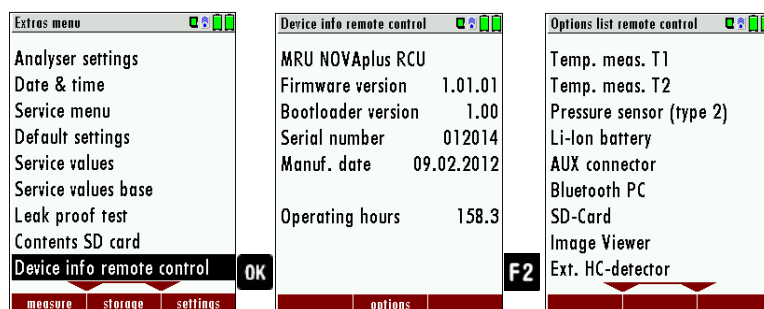

▶ Go to the Ex-

tras menu.

- ▶ Select Device info remote control.
 - ⇒ The menu Device info remote control appears.
- ▶ Press F2.
 - ⇒ The menu Options list remote control appears.

Options list base unit

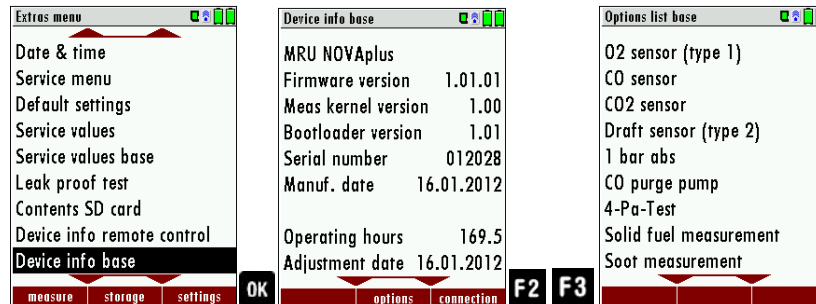

- ▶ Go to the Extras menu.
- ▶ Select Device info base.
 - ⇒ The menu Device info base appears.
- ▶ Press F2.
 - ⇒ Das menu Options list base appears.
- ▶ Press F3.
 - ⇒ The name respectively the MAC address of the connected base unit appears.

9.8. Self diagnostics

The analyser performs a self-diagnosis. The self-diagnosis provides a quick overview of the condition of the batteries and sensors. If the option "Flow control" is installed, the current flow rate [l/min] can be displayed.



Top left: Leak proof test
 Top right: sensor test
 Bottom left: flow control
 Bottom right: Battery status

- ▶ Go to the Extras menu.
- ▶ Select Self diagnostics.
- ▶ Press OK.
 - ⇒ The menu Self diagnostics appears.
- ▶ Press F2.
- ▶ Follow the instructions on the display.

10 Maintenance and care

10.1. Cleaning

The analyser requires very little maintenance to maintain its value over a long period

- occasionally: cleaning the probe and the probe hose.
- after each measurement: Pull off the gas sampling hose on the analyser, so that the hose can dry.
- If not used for a longer period of time, charge the battery first.

10.2. Maintenance

An annual service check and if necessary, adjustment of the sensors at an MRU service department (www.mru.eu) are recommended for the preservation of value.

With optional gas detector: In the case of a use to the pure leakage detection (maximum value search) a function check of the equipment is enough e.g. over an impact from a search gas bottle. A long-term continuous detector accuracy is guaranteed however only by an annually repeated calibration of the equipment.



NOTE

Please note that correct operation of the analyser is only ensured if the sensors are adjusted regularly.

- ▶ Depending on the intensity of use, the sensors have to be adjusted / calibrated 1-2 times a year.

10.3. Service messages

A check of the analyser at our Service Department is necessary: after **1000 working hours** or if it has been more than 11 months since the last check.

When next powered on, you will be reminded to the execution of the annual customer service.

A complete service at an MRU service station (for MRU services station please see: www.mru.eu)

contains the function control and calibration and/or cleaning of the following components:

Sensors, pumps, internal/external hose lines, battery, draft sensor, electronics, time and date, temperature sensors, gas sampling probes, condensate separator



11 Appendix

11.1. Technical data

General data

Deutsch	Angabe / Value	English
Betriebstemperatur	+5°C ... +45 °C 41 °F ... 113 °F	Operating temperature
Rel. Luftfeuchtigkeit bei Betrieb, nicht-kondensierend	95%	Rel. Humidity, non-condensing
Lagertemperatur	-20°C ... +50°C / -4°F ... 122°F	Storage Temperature
Fernbedieneinheit: Akku intern, Betriebszeit	NiMH: 15h Li-Ion: 25h	Remote Control Unit: Internal Battery Pack, operating hours
Grundgerät: Akku intern, Betriebszeit (ohne Gaskühler und Rußsonde)	Li-Ion, 10h	Base unit: internal Battery Pack, oper- ating hours (w/o gas cooler and soot probe)
Stromversorgung Grundgerät	100 - 240 V / 1,4A 12V DC / 5A	Power supply base unit
Stromversorgung Fernbe- dieneinheit: - kontaktlos in der Ladeschale - oder ext. USB Netzteil	• USB 5V 1A	Power Supply Remote Control Unit RCU - wireless charging via base unit, - or USB power supply externally
Gewicht mit 2 Sensoren, Koffer, Sonde, Netzteil	7,4 kg	Weight w/ 2 sensors, case, probe, power supply
Maße inkl. Koffer (BxHxT)	470 x 314 x 235 mm ³	Size incl. Case (WxHxD)
Gehäusematerial Fernbedienung	PA6 GF 30	Housing Material RCU
Schutzart Fernbedienung	IP30	IP degree of protection of remote control
Gehäusematerial Grundgerät	Aluminium	Housing Material Base Unit
Schutzart Grundgerät	IP30	IP degree of protection of Base Unit
Schutzart (Grundgerät geöffnet)	IP20	IP degree of protection (Base Unit open)
max. Unterdruckbereich der Gas- pumpe	350 hPa	Max suction range gas pump
typischer Gasdurchfluss	90 l/h	gas flow typ

Bluetooth frequency range and output power

Bluetooth Frequenzbereich und Ausgangsleistung		Bluetooth frequency range and output power
Fernbedienung (RCU)	BlueMod+SR Bluetooth Dualmode	Remote control (RCU)
	EDR Power @2.402 GHz: 5.5* dBm	
	EDR Power @2.441 GHz: 7.5* dBm	
	EDR Power @2.480 GHz: 8.5* dBm	
	BLE power @2.402 GHz: 5.5* dBm	
	BLE power @2.440 GHz: 7.5* dBm	
	BLE power @2.480 GHz: 8.5* dBm	
	*Typische Werte/typical values	
Fernbedienung (RCU) <-> Grundgerät (Basis)	RN41 Bluetooth Classic	Remote control (RCU) <-> Base unit
	2.402 GHz to 2.480 GHz	
	RF power @ 2.402 GHz: 16.3* dBm	
	RF power @ 2.441 GHz: 17.0* dBm	
	RF power @ 2.480 GHz: 18.4* dBm	
	*Typische Werte / typical values	
Fernbedienung (RCU) <-> Grundgerät (Basis)	RN41N Bluetooth Classic	Remote control (RCU) <-> Base unit
	2.402 GHz to 2.480 GHz	
	2.402 GHz: 11.9* dBm	
	2.441 GHz: 10.9* dBm	
	2.480 GHz: 9.9* dBm	
	*Typische Werte/typical values	

Gas sampling and conditioning

Deutsch	Angabe / Value	English
max. Unterdruckbereich der Gaspumpe	350 hPa	Max suction range gas pump
typischer Gasdurchfluss	90 l/h	gas flow typ
Kondenstafalle (nicht-gekühlt)	Standard	Condensate trap (non-cooled)
Gaskühler	Option	Gas cooler
Temperatur Peltierkühler (an Netz und Akku)	5 °C	Temperature Peltier cooler (during grid and battery operation)
Akkubetriebszeit mit Gaskühler	2,5h (5°C) / 6h (ECO T-Gerät - 10°C)	Batt operating hours with gas cooler
Kondensatentsorgung aus dem Gaskühler	•	Condensate removal from gas cooler
Automat. Feuchtealarm	•	Humidity supervision and alarm
Interne Durchflussmessung	•	internal gas flow measurement

Measurement accuracy data

Deutsch	Angabe / Values	English
Elektrochemischer Sensor	O2	Electrochemical Sensor
Messbereich Standard optional	0 - 21 Vol% 0 - 25 Vol%	Measuring Range Standard optionally
Auflösung	0,1 Vol%	Resolution
Genauigkeit abs.	± 0,2 Vol%	Abs. Accuracy
Ansprechzeit T90	< 20s	Response Time T90
Jahre erwartete Lebensdauer an Luft	2	Years expected lifetime (@air)
Elektrochemischer Sensor	O2 Long Life	Electrochemical Sensor
Messbereich Standard optional	0 - 21 Vol.% 0-25 Vol.%	Measuring Range Standard optionally
Auflösung	0,1 Vol%	Resolution
Genauigkeit abs.	± 0,2 Vol.%	Abs. Accuracy
Ansprechzeit T90	< 20s	Response Time T90
Jahre erwartete Lebensdauer an Luft	5	Years expected lifetime (@air)
Elektrochemischer Sensor	CO	Electrochemical Sensor
H2 - kompensiert		H2 compensated
Nominaler Messbereich	0 - 4000 ppm	Nom. Measuring Range
Überlastbereich	< 10000 ppm	Overload Range
Auflösung		Resolution
Genauigkeit absolut / vom Messwert	± 10 ppm/ 5% (0 .. 4000 ppm) 10% (> 4000 ppm)	Accuracy abs. / reading
Ansprechzeit T90	< 40s	Response Time T90
Option	CO low	Option
Messbereich	300 ppm	Measuring Range
Auflösung	0,1 ppm	Resolution
Genauigkeit absolut / vom Messwert	2,0 ppm 5%	Accuracy abs. / reading
Elektrochemischer Sensor	CO high	Electrochemical Sensor
Nominaler Messbereich	0 - 4000 ppm	Nom. Measuring Range
Überlastbereich	< 20000 ppm	Overload Range
Auflösung		Resolution

Genauigkeit absolut / vom Messwert	± 100 ppm / 5% (0 ... 4000 ppm) 10 % (> 4000 ppm)	Accuracy abs. / reading
Ansprechzeit T90	< 40s	Response Time T90
Elektrochemischer Sensor	NO	Electrochemical Sensor
Nominaler Messbereich	0 - 1000 ppm	Nom. Measuring Range
Überlastbereich	< 5000 ppm	Overload Range
Auflösung		Resolution
Genauigkeit abs. /vom Messwert	± 5ppm / 5% (0 ... 1000 ppm) 10% (> 1000 ppm)	Accuracy abs./reading
Ansprechzeit T90	< 30s	Response Time T90
Option	NO _x low	Option
Messbereich	300 ppm	Measuring Range
Auflösung	0,1 ppm	Resolution
Genauigkeit abs / vom Messwert	2,0 ppm 5%	Accuracy abs. / reading
Elektrochemischer Sensor	NO ₂	Electrochemical Sensor
Nominaler Messbereich	0 - 200 ppm	Nom. Measuring Range
Überlastbereich	< 1000 ppm	Overload Range
Auflösung		Resolution
Genauigkeit abs. /vom Messwert	± 5ppm / 5% (0 ... 200 ppm) 10% (> 200 ppm)	Accuracy abs./reading
Ansprechzeit T90	< 40s	Response Time T90
Elektrochemischer Sensor	SO ₂	Electrochemical Sensor
Nominaler Messbereich	0 - 2000 ppm	Nom. Measuring Range
Überlastbereich	< 5000 ppm	Overload Range
Auflösung		Resolution
Genauigkeit abs. / vom Messwert	± 10ppm / 5% (0 ... 2000 ppm) 10% (> 2000 ppm)	Accuracy abs./reading
Ansprechzeit T90	< 40s	Response Time T90
Elektrochemischer Sensor	H ₂ S	Electrochemical Sensor
Nominaler Messbereich	0 - 500 ppm	Nom. Measuring Range
Überlastbereich	< 2000 ppm	Overload Range
Auflösung Standard Für Option H ₂ S low	1 ppm 0,1ppm	Resolution for option H ₂ S low

Genauigkeit abs. /vom Messwert	± 5 ppm / 5% (0 ... 500 ppm) 10% (> 500 ppm)	Accuracy abs./reading
Ansprechzeit T90	< 40s	Response Time T90
Nicht-dispersive Infrarotmessung (NDIR)	CO ₂	Non-dispersive Infrared Measurement (NDIR)
Nominaler Messbereich	0 - 50 Vol%	Nom. Measuring Range
Auflösung		Resolution
Genauigkeit abs. /vom Messwert	± 0,3 Vol% / 5%	Accuracy abs./reading
Ansprechzeit T90	< 35 s	Response Time T90
Nicht-dispersive Infrarotmessung (NDIR)	CO/CO ₂ /CH ₄ CO/CO ₂ /C ₃ H ₈	Non-dispersive Infrared Measurement (NDIR)
Technische Daten siehe zugrundeliegende Küvette ArtNr 12718 & 12813, S.85		Technical data see underlying cuvette ArtNr 12718 & 12813, p. 85.
Abgastemperatur	T _A	Flue gas temperature
Messbereich mit Gasentnahmerohr aus Edelstahl	0 - 800°C	Measuring Range with high grade steel probe pipe
Messbereich mit Gasentnahmerohr aus Inconel	0 - 1100°C	Measuring range with Inconel probe pipe
Genauigkeit abs. / vom Messwert	±2°C / 1%	Accuracy abs. / reading
Anschluss an Basisgerät		To be connected to base unit
Verbrennungslufttemperatur	T _i	Air temperature
Messbereich	0 - 100°C	Measuring Range
Genauigkeit abs.	1 °C	Accuracy
Anschluss an Grundgerät oder optional an Fernbedieneinheit		To be connected to base unit or optional to remote control unit
Kaminzug		Draft
Messbereich	± 120 hPa	Measuring Range
Auflösung	0,1Pa	Resolution
Genauigkeit abs. / vom Messwert	0,02 hPa / 1%	Accuracy abs. / reading
Differenzdruck Basis		Differential Pressure Base Unit
Messbereich	± 120 hPa	Measuring Range

USER MANUAL NOVaplus

Auflösung	0,1Pa	Resolution
	0,02 hPa /	
Genauigkeit abs. / vom Messwert	1%	Accuracy abs. / reading
Anschluss an Grundgerät		To be connected to base unit
Differenzdruck RCU		Differential Pressure RCU
Messbereich	± 120 hPa	Measuring Range
Auflösung	0,1 Pa	
	0,02 hPa /	
Genauigkeit abs. / vom Messwert	1%	Accuracy abs. / reading
Anschluss an Fernbedieneinheit		To be connected to Remote Control Unit
Differenzdruck RCU		Differential Pressure RCU
Messbereich	± 300 hPa	Measuring Range
Auflösung	1 Pa	
	0,1 hPa /	
Genauigkeit abs. / vom Messwert	2%	Accuracy abs. / reading
Anschluss an Fernbedieneinheit		To be connected to Remote Control Unit
Temperaturmessung RCU		Temperature Measurement RCU
Messbereich	-50 ... 1100 °C	Measuring Range
Thermoelement	Typ K Mini	Thermocouple
Barometrischer Druck	P_{abs}	Barometric Pressure
Messbereich	300 ... 1200 hPa	Measuring Range
Genauigkeit	± 3 hPa	Accuracy

Nicht-dispersive Infrarotmessung (NDIR)			CH ₄ / CO / CO ₂	Non-dispersive Infrared Measurement (NDIR)	
ArtNr.	Gas	Messbereich / Range	Auflösung / Resolution	Genauigkeit / Accuracy	T90
12718	CO	2000ppm...10 Vol. %	1 ppm	± 20ppm / 2%	40s
	CO ₂	50 Vol. %	0,01 Vol. %	± 0,1 Vol. % / 2 %	
	CH ₄	2000ppm ... 4 Vol. %	1 ppm	± 10ppm / 2 %	

Nicht-dispersive Infrarotmessung (NDIR)			C ₃ H ₈ / CO / CO ₂	Non-dispersive Infrared Measurement (NDIR)	
ArtNr.	Gas	Messbereich / Range	Auflösung / Resolution	Genauigkeit / Accuracy	T90
12813	CO	2000ppm...10 Vol. %	1 ppm	± 20ppm/ 2%	40s

	CO ₂	50 Vol. %	0,01 Vol.%	± 0,1 Vol.% / 2 %	
	C ₃ H ₈	2000ppm ... 4 Vol.%	1 ppm	± 10ppm / 2 %	

11.2. Calculated values

Deutsch	Angabe	English
	CO ₂	
Messbereich (brennstoffabhängig)	0 - CO ₂ max	Measuring range (fuel type dependant)
Genauigkeit abs.	± 0,3 Vol.%	Accuracy abs.
Taupunkt	°C	Dew point
Abgasverlust qA	0 - 99,9%	Losses qA
Wirkungsgrad	0 - 120%	Efficiency
Messwerte darstellbar als	mg/Nm ³ O ₂ Ref. mg/kWh NOx: mg/Nm ₃ NO ₂	Measurement values available as
Stömungsgeschwindigkeit	v	Velocity
basierend auf Differenzdruckmessung mit Prandtlrohr		based on differential pressure measurement with Pitot tube
Messbereich	1 m/s ... 100 m/s	measuring range
Genauigkeit ohne Fehler des Prandtrohrs	±1m/s(0<v<2m/s) ±0.2 m/s (2<v<10m/s) ±0.5 % (v>10m/s)	Accuracy without error of Pitot tube
Auflösung	0,1 m/s	resolution
Absolutdruckmessung	•	absolute pressure measurement
basierend auf Flügelradmessung		based on vane anemometer
Messbereich (abhängig von Flügelrad-Typ)	0,25 - 35 m/s	measuring range (depending on actual vane type)
externer Drucksensor	Angaben	external pressure sensor
	#63684	
Messbereich	5 bar	Range
Auflösung	1 mbar	Resolution
Genauigkeit abs. / vom Messwert	10 mbar / 1%	Accuracy abs. / reading
	#63685	

Messbereich	25 bar	Range
Auflösung	1 mbar	Resolution
Genauigkeit abs./ vom Messwert	50 mbar / 1%	Accuracy abs. / reading
	#63686	
Messbereich	40 bar	Range
Auflösung	1 mbar	Resolution
Genauigkeit abs. /vom Messwert	100 mbar / 1%	Accuracy abs./reading
Feuchte- & Temperatursonde	RH	Humidity & Temperature Probe
Messbereich Feuchte	3 - 98 %	Measuring Range Humidity
Genauigkeit Feuchtemessung abs.	± 3% RH	Accuracy Humidity Measurement
Messbereich Umgebungstemperatur	-20 °C ... +80°C	Measuring Range Ambient Temperature
Genauigkeit Umgebungstemperaturmessung	± 1°C	Accuracy Ambient Temperature Measurement
Gasleitungsprüfung - Belastungsprüfung		
Messbereich	0 - 1500 mbar	
Genauigkeit (abs. / vom Messwert)	±4 mbar / 2%	
Gasleitungsprüfung - Dichtheitsprüfung		
Messbereich	0 - 200 mbar	
Genauigkeit (abs. / vom Messwert)	±0,5 mbar / 3%	
Gasleitungsprüfung - Gasleckmenge		
Messbereich	0 - 8 l/h	
Genauigkeit (abs. / vom Messwert)	±0,2 l/h / 5%	
Gaslecksuche		Gas Sniffer
Messbereich CH ₄	5 - 20000 ppm	Measuring Range CH ₄
Überlast	100000 ppm	Overload
Auflösung	1 ppm	Resolution
Ansprechzeit	T ₉₀ < 5s	Response Time

Data communication

Deutsch	Angabe /Value	English
USB Anschluss	via RCU	USB interface
SD Karte für SW update, Datenaustausch, erweiterter Datenspeicher	>= 2GB, via RCU	SD card for SW update, data exchange or extended data memory
Reichweite Funkverbindung RCU - Grundgerät freie Sicht typisch in Gebäuden (situationsabhängig)	100 m 20 m	Range of link RCU to base unit free air typical inside buildings (depending an actual situation)

11.3. Analysis and calculations

Measured values	Unit
O ₂	[%]
Temp. Ambient air (Thermo-Element)	[°C]
Temp. Flue gas (Thermo-Element)	[°C]
CO	[ppm]
Draft	[hPa]
Available conversions of CO	CO
[ppm] related to. on 0% rest O ₂ (undiluted)	X
[ppm] related to. on fuel type dependent O ₂ reference value	X
[mg/m ³]	X
[mg/kWh]	X
[mg/MJ]	X
[mg/m ³] on fuel type dependent O ₂ reference value	X

Continously caculated values	Unit
CO ₂	[%]
Efficiency ETA	[%]
Efficiency condensed	[%]
Losses	[%]
Losses condensed	[%]
Lambda	-
Dew point	[°C]

Losses and efficiency are calculated by means of net calorific value. These values are than referenced for the gross calorific value for condensing boilers only. (efficiency > 100)

The calculations of efficiency and exhaust losses are performed using Siegert's formula.

For further information please contact MRU GmbH

11.4.Fuel type list

Deutschland		O2max	20,96	
Brennstoff	CO2max	A1	A2	B
Prüfgas	0,0	0,00	0,00	0,000
Erdgas (LL)	11,8	0,37	0,66	0,009
Erdgas (E) (*)	12,1	0,37	0,64	0,009
Heizöl EL	15,4	0,50	0,68	0,007
Heizöl S	15,9	0,50	0,66	0,007
Flüssiggas P/B	13,7	0,42	0,63	0,008
Propan	13,7	0,43	0,66	0,007
Butan	14,1	0,45	0,67	0,007
Bio-Diesel	15,7	0,46	0,62	0,005
Holz trocken	20,3	0,60	0,62	0,009
Pellets	20,3	0,74	0,77	0,000
Kohle	19,1	0,59	0,65	0,009
Braunkohle	19,4	0,39	0,42	0,009
Torf	19,8	0,66	0,70	0,010
Kokereigas	10,8	0,29	0,60	0,011
Stadtgas	11,7	0,35	0,63	0,011

Österreich		O2max	21,00	
Brennstoff	CO2max	A1	A2	B
Prüfgas	0,0	0,00	0,00	0,000
Heizöl EL	15,3	0,52	0,71	0,007
Heizöl L	15,8	0,53	0,70	0,007
Heizöl M + S	16,1	0,54	0,70	0,007
Erdgas H	11,9	0,39	0,68	0,009
Erdgas H gebf.	11,9	0,41	0,72	0,009
Propangas g31	13,7	0,45	0,69	0,007
Prop. g31 gebf	13,7	0,47	0,72	0,007
Butan	14,1	0,45	0,67	0,007
Zechenkoks	20,6	0,74	0,75	0,001
Holz trocken	19,4	0,60	0,65	0,009

Fuel lists for further countries receive you on requirement or on our Internet site: www.mru.eu

11.5. Text input

A number of texts and names can be changed to your own needs.
(for example: the names of the user defined fuel types, site names, the names of the measurement programs)

When you select the text input, the following window will pop up:

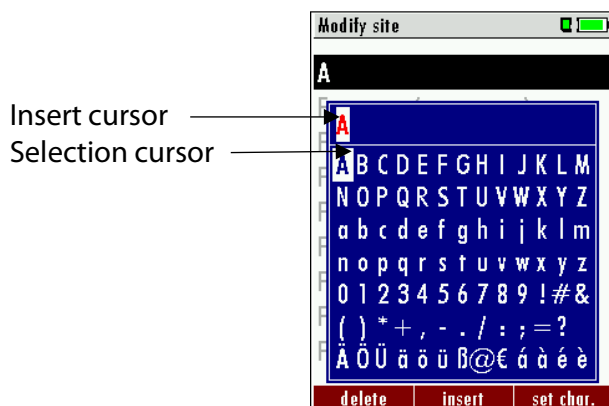

▲, ▼, ◀, ▶	Select a letter, number or sign
F1 – delete	The letter left of the cursor will be deleted
F2 – insert	Selected letter or number will be inserted
F3 – over write	Selected letter or number will over write the current letter or number
ESC	Abort the window, changes will NOT be saved

11.6. Asking user for decision

The analyser requires confirmation of the user decision for various functions

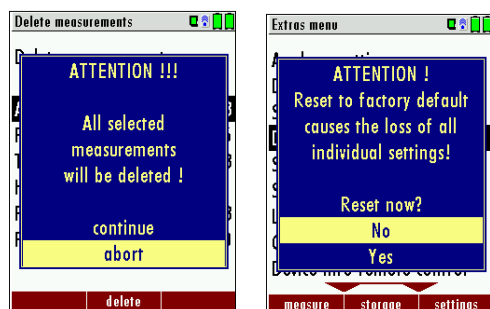

▲, ▼	Select a line
OK	Confirm the action
ESC	Abort the window, changes will NOT be saved

11.7. Firmware update

NOTE



During the Firmware update the LED of the ON-OFF switch (Base unit) is flashing and the Bluetooth connection symbol changes the colour from blue to yellow.

Don't press during the update any key and remove the SD card first after a restart of the base unit from the device!

- ▶ Switch OFF the device.
- ▶ Select F3 settings/Device info remote control

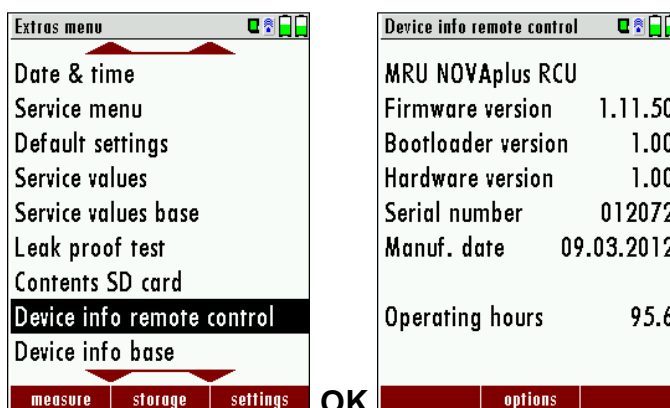

The first line shows e.g.: Firmware-Version 1.11.50

Following select Device info base

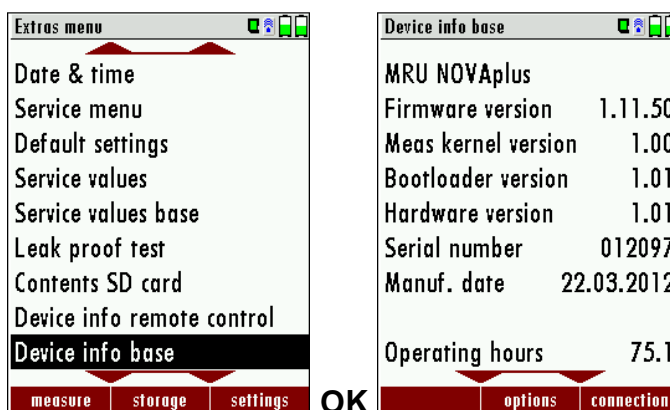

For the case that there should be problems by the update we need some information of you.

RCU:

Please write down your Firmware-Version

(e.g. 1.11.50)

Please write down your serial number

(e.g. 012072)

Base unit:

Please write down your Firmware-Version

(e.g. 1.09.01)

Please write down your serial number

(e.g. 012039)

Do the following steps in order to update the firmware:

- ▶ copy the files '1093Base.fwb' and '1093RCU.fwb' to a SD card in the root directory (that means in no directory), in case you received the files in a zip archive you'll have to decompress it first
- ▶ switch on the analyser (Base and remote control) and verify whether the connection is OK (blue symbol)
- ▶ insert the SD card into the remote control
- ▶ you will be asked: 'Firmware for base found. Install now?'
- ▶ acknowledge with 'install'
- ▶ the base update will be started and will take about 1 minute, while you will here several beeps
- ▶ then you will be asked: 'Firmware for remote control found. Install now?'
- ▶ acknowledge again with 'install'
- ▶ the remote control update will be started and will take about half a minute, while the display remains empty
- ▶ finished

How do I identify if the update was successful?

- ▶ Switch on the analyser.
- ▶ Go to the Extras menu
- ▶ Select Device info.
 - ⇒ In the first line the new firmware version must be displayed

11.8. Troubleshooting

Troubleshooting the analyser

1. Effect	2. Error indication	3. Cause	4. Solution
Device cannot be switched off by pressing the OFF key.	LED behind the condensate separator is on and the LCD display is dark	Device does not react on any key.	Press ESC and ON simultaneously! EMERGENCY OFF After this, the date and time have to set new.
Inside of the device is too cold, device not ready for operation.	Display indication: "Device too cold" or audible sound every 5 sec..	e.g. device was stored in a cold place during winter.	Put the device to a warm room and wait
Measuring values are not correct		Sensors already get in touch with the gas during calibration.	Vent device with fresh air and re-start!
No measurement possible		Device cannot be switched on or does not react after being switched on. Battery discharge	Connect the device to the line power in order to charge the battery.
Measurement without exact temperature values.	Temperature indication: ---, - °C	Thermo element defective, balancing network interrupted or not connected.	Call our after-sales service. Remove probe from the gas duct and condensate from the probe tube.
Wrong measuring values	Measuring range exceeded: Value O ₂ too high Values CO and CO ₂ to low	Connection probe – device not correct. Leakage at probe / tube / condensate separator, pump does not suck correctly	Effect tightness test! By visual control of probes, tubes condensate separator, leaking parts could be found.
Wrong measuring values	Gas temperature is too hot or alternates	Probe is not plugged in correctly, defective cable in the probe line, formation of condensate at the probe tip.	Check probe plug respectively probe line regarding damages (loose connection), remove condensate from the probe tip.

Troubleshooting condensate separator

1. Effect	2. Cause	3. Solution
Dirt and / or humidity inside the device No filter effect Sensor failure Pump failure	Fine filters are wet and / or dirty.	Check filters more often Renew them if necessary (white = OK) Brown-black = renewal
Wrong measuring values	Cover, intermediary unit, plexiglass tube and locking pieces are not tightly fixed respectively screwed	Check tightness with every filter change.



MRU GmbH, Fuchshalde 8 + 12, D-74172 Neckarsulm-Obereisesheim
Phone +49 71 32 99 62-0, Fax +49 71 32 99 62-20
email: info@mru.de * site: www.mru.eu

Managing director: Erwin Hintz
HRB 102913, Amtsgericht Stuttgart
USt.-IdNr. DE 145778975