



# **PROSENSE PPS+ Series Gas Detectors Installation and User Manual**

## **WARNING!**

**This manual must be carefully read by all persons who have or will have the responsibility for installing, using or servicing this product.**

**Like any equipment, this product will perform as designed only if installed, used and serviced in accordance with the manufacturer's instructions. Otherwise, it could fail to perform as designed and persons who rely on this product for their safety could suffer severe personal injury or death.**

**The warranties made by Prosense with respect to this product are voided if the product is not installed, used and serviced in accordance with the instructions in this user guide. Please protect yourself and other by following them.**

**Contents**

- For Your Safety ..... 4
  - Strictly follow the Instructions for Use ..... 4
  - Maintenance ..... 4
  - Liability for proper function or damage..... 4
  - Intended Use ..... 4
- Introduction ..... 5
- Detector body ..... 6
- Sensor Head: ..... 7
- Installation: ..... 7
- Mounting the detector:..... 8
- Cabling and Connections ..... 9
- PPS+ Series CO and NO2 Detectors Connections ..... 11
- System Status ..... 13
- First time switch on (Commissioning) ..... 13
- Calibration ..... 14
  - Zero Calibration ..... 17
  - Span Calibration ..... 18
- Maintenance ..... 18
  - Proactive Maintenance: ..... 18
  - Operational Life:..... 18
  - Servicing ..... 18
  - Filter Replacement: ..... 18
  - Sensor Replacement:..... 19
  - Sensor Head Replacement: ..... 20
- General specification..... 20
- Certificate..... 21
- Declaration ..... 23
- Warranty statement..... 24

## For Your Safety

Ensure that this Operating Manual is read and understood **BEFORE** installing / operating / maintaining the equipment. Pay particular attention to Warnings and Cautions. All document Warnings are listed here and repeated where appropriate at the start of the relevant chapter(s) of this Operating Manual. Cautions appear in the sections/sub-sections of the document where they apply.

### Strictly follow the Instructions for Use

Any use of the detectors requires full understanding and strict observation of these instructions. The detector is only to be used for purposes specified here.

### Maintenance

It is recommended to obtain a service contract Prosense to carry out all repairs. Only authentic Prosense spare parts should be used for maintenance.

### Liability for proper function or damage

The liability for the proper function of the detector is irrevocably transferred to the owner or operator to the extent that the detector is serviced or repaired by personnel not employed or authorized by Prosense or if the sensing head is used in a manner not conforming to its intended use. Prosense cannot be held responsible for damage caused by non-compliance with the recommendations given above. The warranty and liability provisions of the terms of sale and delivery of Prosense are likewise not modified by the recommendations given above.

### Intended Use

The PPS+ series detectors are intended to be used for stationary, continuous monitoring for toxic gas/air in closed area car parks under atmospheric conditions.

### Not to be used in oxygen enriched atmospheres

In conjunction with the central controllers Prosense detectors with preadjusted alarm thresholds audible and visible alarm devices or automatic countermeasures can be activated before the detected gases or vapours can form dangerous mixtures with air.

If a gas alarm occurs, necessary actions need to be taken immediately. The decrease of the measuring signal should not mean that the gas concentration has been decreased. We recommend to keep alarms on the associated controllers and not to reset these alarms without performing measurement with an independent gas detector to make sure conditional are safe.

### Important Remark

**The detector has been calibrated and factory-tested before delivery. The commissioning has to be terminated by a function test of the complete gas detection system.**

## Introduction

Prosense developed a complete solution for closed area car parks like underground parking areas and road tunnels. Vehicles release CO and NO<sub>2</sub> during initial start-up. These gases tend to accumulate a lot in parking area and in enclosed spaces. CO and NO<sub>2</sub> gases must be constantly monitored in these areas for health and safety reasons. If the ventilation in these areas not adequate, CO and NO<sub>2</sub> gases can reach high concentration levels and cause a number of damages including nausea and vomiting due to the high concentrations and can cause to death.

Prosense provides special detectors to monitor CO and NO<sub>2</sub> gas concentration in enclosed car parking areas. Detectors equipped with high quality electrochemical sensors for the toxic gas detection that can show excellent output in ppm range for Carbon Monoxide, Nitric Oxide and Nitrogen Dioxide gases.

PPS+ series detectors have on board RS 485 (Modbus) communication protocol that provides a great advantage for cabling and installation. Prosense PPS+ series gas detectors can connect to Prosense PPS Manager gas control panel which has been developed specifically for car parks. PPS Manager Series gas control panels with flexible structure capacity and expandable even after installation.

PPS Manager Gas control panel can have up to 4 zone modules and each zone can monitor up to 32 detectors. A fully populated PPS Manager gas control support up to 128 different detectors. Toxic and flammable gas detectors should be installed separate zone modules. PPS Manager automatically recognizes the detectors. There is no need to make any special settings for each detector.

Prosense PPS+ series comprises a gas detector body and sensors head for detecting flammable and toxic gases.

## Detector body

Prosense detectors comprises of the main parts as shown below:

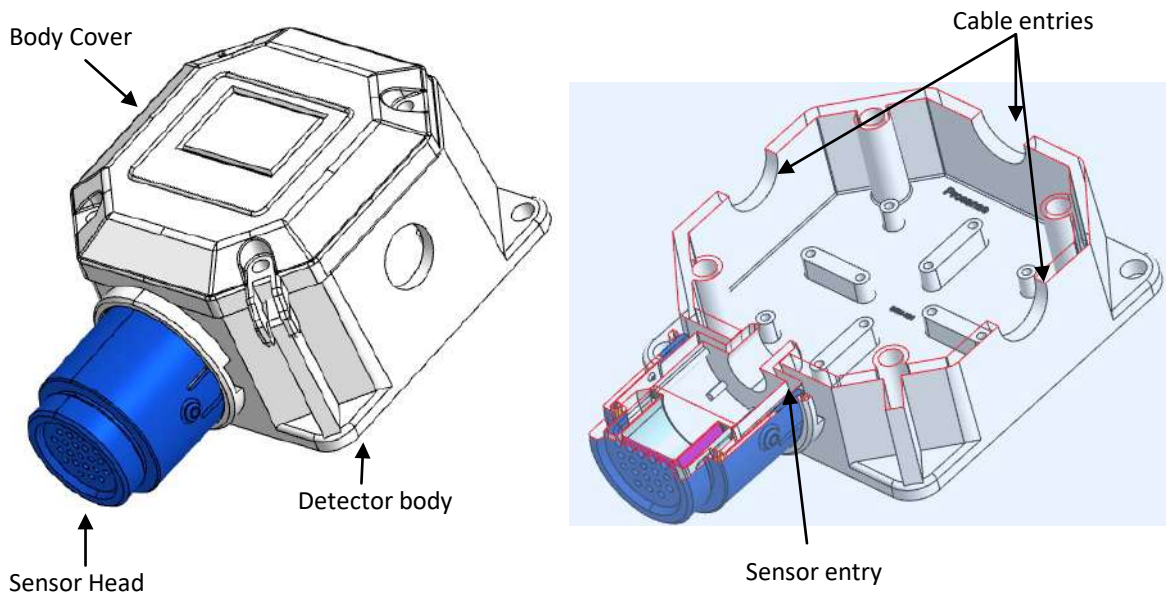

**Diagram 1: Exploded view**

The detector enclosure has four entries. The three cable entries either side of the upper part of the transmitter housing are for connecting the power source, signal output and relay contacts to associated signalling equipment. The bottom entry allows direct connection of the sensor socket. The body has integrated mounting screw locations on housing.

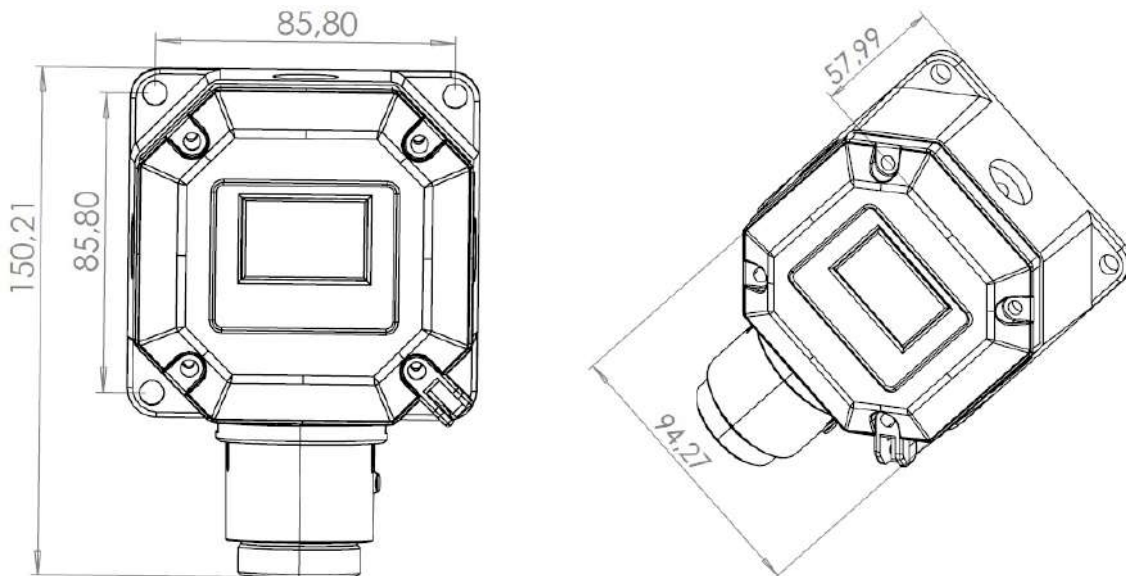

**Diagram 2: Detector body and Sensor Head size**

## Sensor Head:

The Prosense PPS+ series sensor head designed to detect flammable and toxic gases. Sensor head in PPS+ series may include a wide range of toxic gas sensors based on electrochemical cell (ECC) technology.

## Installation:

Gas detectors should be mounted where a potential hazard of gas is most likely to be present. The following points should be noted when locating gas sensors.

- When locating detectors consider the possible damage caused by natural events e.g. rain or flooding.
- Consider ease of access to the gas detector for functional testing and servicing.
- Consider how escaping gas may behave due to natural or forced air currents.

**Note:** The placement of gas detectors should be determined following the advice of experts having specialist knowledge of gas dispersion, experts having knowledge of the process plant system and equipment involved safety and engineering personnel. The agreement reached on the location of detectors should be recorded.

Each gas has different nature depending on their density. The density of which is lower than air, such as hydrogen, methane or ammonia the sensor head must be located above a possible leak or at the highest points at which major concentrations of gas may be found. The gases and vapours with a density greater than air, the sensor head must be installed beneath a possible leak or at the lowest points at which such gases and vapours may be present. The density of which is higher than air such as NO<sub>2</sub> the sensor head must be located where gas accumulate.

Table 1 gives best practice recommendations on where to install the PPS+ series detectors depending of the gas type.

Gas	Recommended mounting location
CO	150cm from floor
NO <sub>2</sub>	30cm from floor

**Table 1: Recommended detector installation location**

## Mounting the detector:

The detector should be mounted vertically as the sensor head pointing downwards. Detector has to be mounted such that the sensor's gas entrance area.

The install location

- should be isolated from vibration, direct sun light and have temperature stability
- avoided external influences such as splashing water, oil, corrosive aerosols
- should have at least 30 cm free space beneath the sensor head to provide accessibility for calibration work.
- should be in air flow between possible leak or collection point and possible source of ignition.

Prosense do not recommend installing detectors to:

- directly above a cooking unit,
- directly above a sink unit,
- close to an extractor unit,
- outdoor without protection against the rain,
- in places where temperature is outside the admissible operating range,
- in corrosive environments,
- inside air vents.
- in environments where silicon can be found.

The Prosense detector has an integrated mounting screw holes on the body. The correct mounting position is given in diagram4:

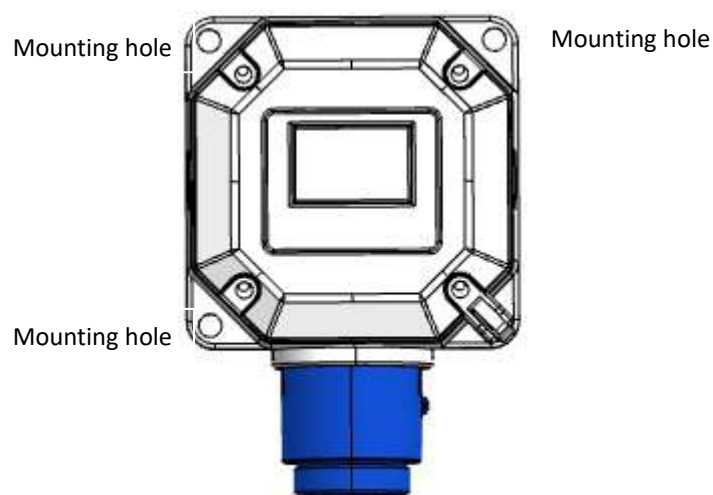

**Diagram 3: Mounting holes on body**

## Cabling and Connections

**Caution: All electrical connections should be made in accordance with any relevant local or national legislation, standards or codes of practice.**

Prosense detectors can operate between 12 - 24 VDC. The connection socket is located on main board. User should consider the cable length when performing installation in the field. Please consider the cable length when performing installation in the field. The Prosense detector requires a power supply between 12VDC and 24VDC. Make sure that a minimum 12 VDC supply available at the detector entrance and consider the voltage drop due to cable resistance in case of long distance applications.

The use of industrial grade, suitably shielded field cable is recommended. The best practices shown that, screened 4 cores (plus screen 90% coverage), suitably mechanically protected copper cable with a suitable gland gives good results depending on the distance between signal received or control panel and detector. It is recommended to use 1.5 mm<sup>2</sup> (16 AWG) cable to provide power to detectors. The total distance from PPS+ Manager Panel zone module to last detector should not exceed 800m. Ensure the cable gland is installed correctly and fully tightened. Detectors and PPS+ Manager Control panel communicates via RS485 communication protocol. Each PPS+ panel zone module can manage up to 32 PPS+ series CO and NO<sub>2</sub> detectors via RS485 serial connection.

V+, V-(GND), A and B ports must be connected via using four-wire cable. Detector connections supply 16VDC power to detector and read the output signal of detector from A and B ports. Thus connections should be made correctly with extra care to do not mix ports and not cause any damage on the detectors. Detector power connection should be done with 1.5mm<sup>2</sup> cross section cable. The total distance between control panel and detectors should not exceed 800 meters. Detector connections should be made with 4 core cable wire that 2 for power and 2 for RS485 and pin definitions are as follows:

Port	Usage	Details
V+	output	+16VDC (Only for panel and detectors, do not use for any other device)
V-	output	-VDC (GND)
A	input	RS485 port A
B	input	RS485 port B

**Table 2: Connection pins and definitions**

The wiring for detectors utilized with RS485 board should be done by using connection cable EIA RS485 2 core wires with section 0.22 / 0.35 mm<sup>2</sup> and shielded. Nominal capacity between the wires should be < 50pF/m and nominal impedance 120 Ohms.

The V+, V- ports and A, B ports are located on same socket in PPS+ panel zone module. These ports are formed together on Prosense PPS+ series detectors on detector main board. The connections should be done with care to do not mix power and RS485 ports. All detectors will

be connected through one cable via hopping one detector to another till the last detector on the line.

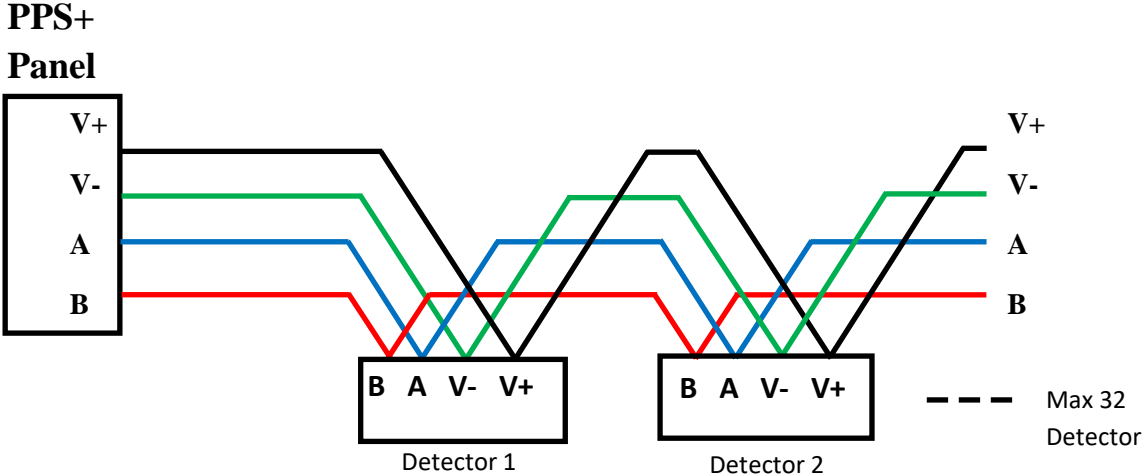

Diagram 4: Panel to detector connections

There should be one master device and up to 32 slave devices in RS485 communication. The master is DP32 control panel and detectors will be the slave devices:

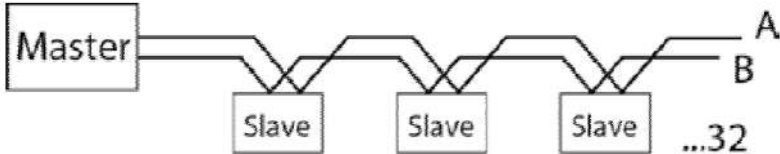

Diagram 5: RS485 communication

Each detector connected to same PPS+ panel should have unique address. Detectors having same address would not be recognised by control panel. PPS+ panel can communicate up to 32 detectors. In case less than 32 detectors connected, control panel would not show non-existent detectors. Unused detectors should be deactivated on channel settings menu steps.

The **last** detector at the RS485 serial line should have the end of line resistor to enable the total communication line. Otherwise control panel may not communicate to all, some or none of the detectors. The end of line resistor controlled by end of line pins located on Prosense PPS+ series detectors and can be enabled via putting the jumper on end of line pins.

## PPS+ Series CO and NO2 Detectors Connections

Prosense PPS+ series detectors has onboard RS485 Modbus serial communication module. The board has 4 ports thus the detector connection should be made by 4 wire that 2 for power and 2 for RS485. The total length of the connection line should not exceed 800 meters.

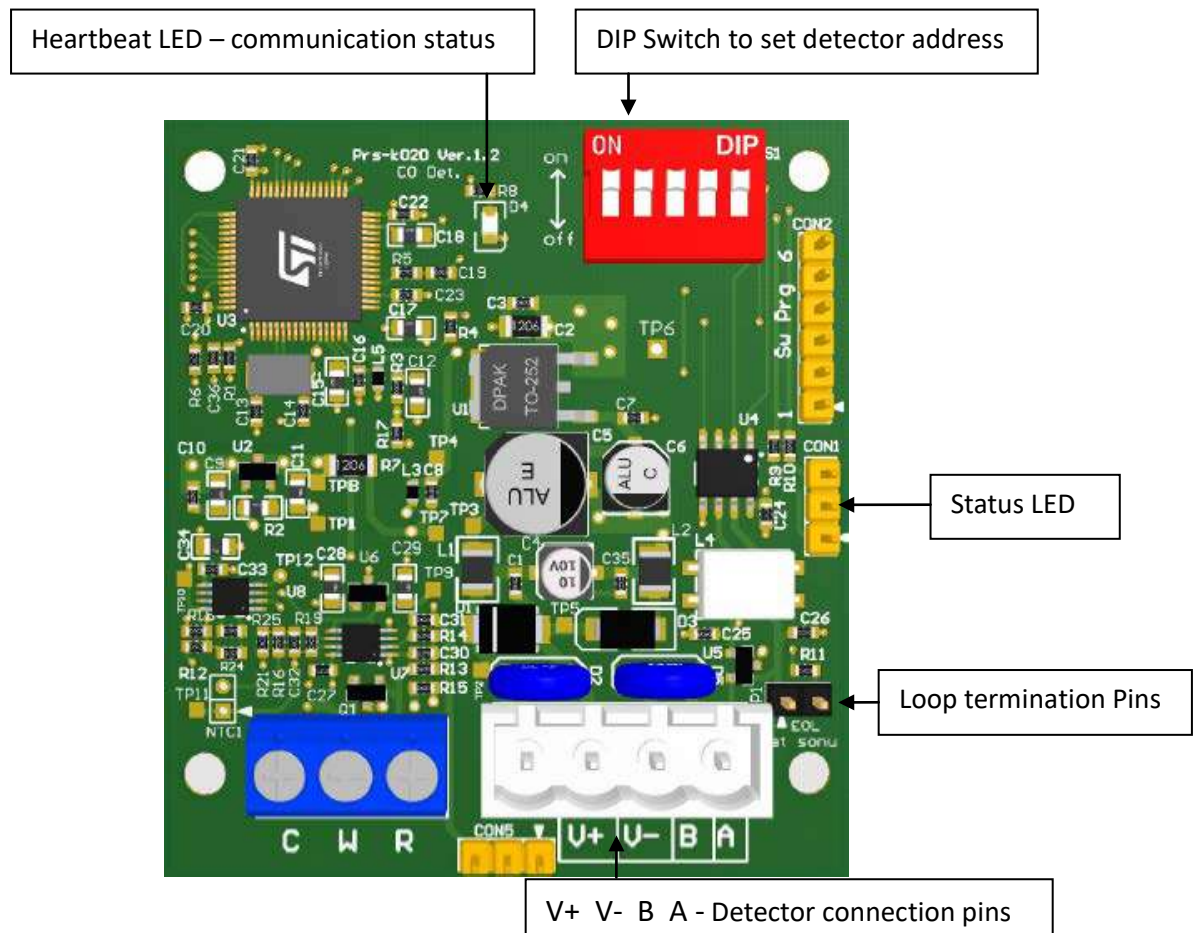

Diagram 6: CO and NO2 detector main board

The wiring for detectors utilized with RS485 board should be done by using connection cable EIA RS485 2 core wires with section 0.22 / 0.35 mm<sup>2</sup> and shielded. Nominal capacity between the wires should be < 50pF/m and nominal impedance 120 Ohms.

Detectors will be wired in daisy chain (bus) mode. We recommend not using star mode connection due to negative impact of interference. Each detector should have unique address number in the chain. The detectors would not be recognised by control panel if same address given to them. The address of detector can be adjusted via using DIP-Switch set on the board:

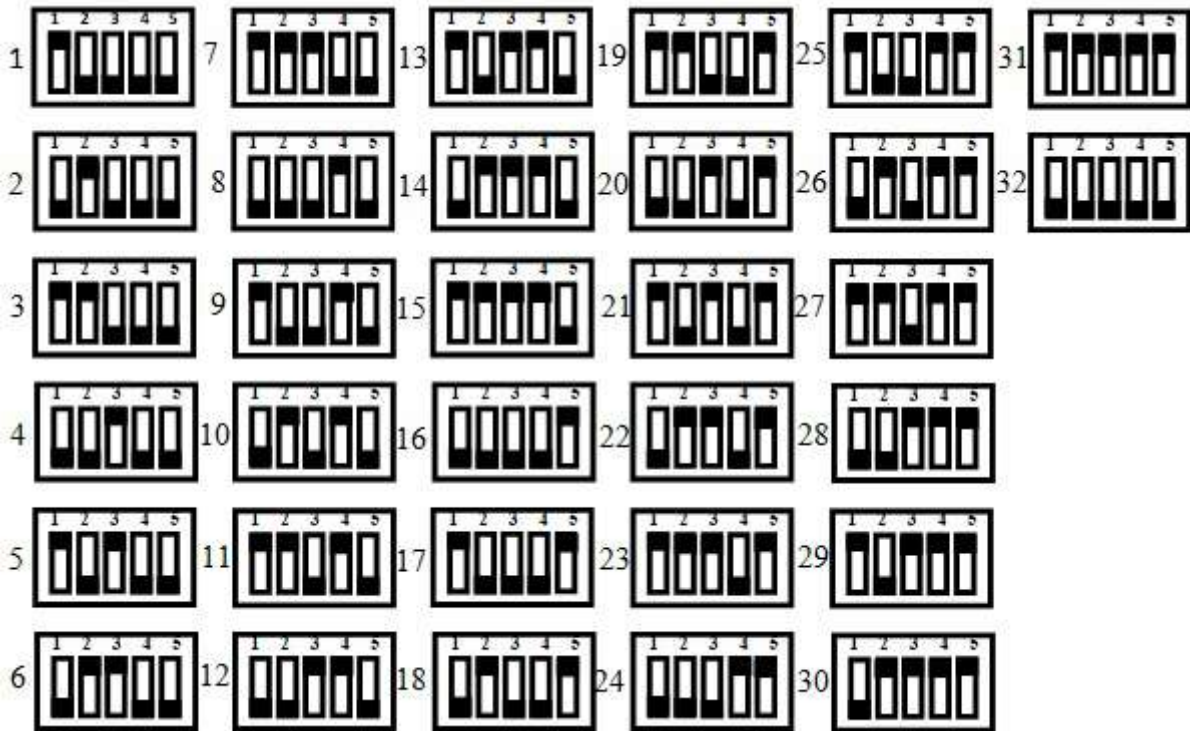

Diagram 7: RS485 Modbus serial communication address and switch position

The last detector in the chain should have 120 Ohms RS485 termination resistor. The resistor is already implemented on the board by default but not activated. User should activate the termination resistor via using the termination pin on “Loop termination pins” once the installation completed.

**Important:** Only the last detector on the serial bus should have jumper on the termination pin.

## System Status

Prosense PPS+ Series detectors have one LED that can illuminate red and green showing detector status and one red LED on main board showing heartbeat status. The status LED will be activated as solid green following power applied. It takes 60 seconds to detector to be ready to normal operation. The LED will stay solid green during warm-up time. Then it will start blinking if there is no fault. If detector has a problem the status LED will stay solid green.

The state LED will be solid red in case of alarm. Once the detector measurement level reached to defined alarm level the status LED will solid red and will return back green blinking when measurement level decreased below alarm threshold.

The heartbeat LED on main board will start blinking following power and stay blinking if detector can communicate to control panel. If heartbeat LED is not blinking it means there is a problem communication to the control panel.

### First time switch on (Commissioning)

#### **WARNING**

The following procedure requires the detector cover to be removed while carrying out supply voltage checks. Therefore the appropriate permits to work should be sought in preparation. Prior to carrying out any HOT WORK ensure local and site procedures are followed. Ensure that the associated control panel output actuation is inhibited so as to prevent false alarms.

**Caution: The following procedure should be followed carefully and only performed by suitably trained personnel**

1. Remove the detector cover
2. Configure the detector's analogue output signal and power input connections done correctly
3. Check that all electrical connections are terminated correctly
4. Switch On the external power supply to feed the detector. If it is connected to PPS+ Manager, cables should be installed according to PPS+ Panel user manual as panel can provide both power and communication connections to the detectors.
5. Using a Digital Multi Meter (DMM), check the Supply Voltage at the terminals V+ and V- this should be a minimum supply voltage of 12VDC (Maximum supply voltage is 24VDC). PPS+ Manager provides around 16VDC power to detectors.
6. Check LED status on detector main board. Status LED should be solid green during the warm-up time. After 60 seconds the status LED should start blinking green. If status LED stays solid green after 3 minutes detector should be controlled again. Following warm-up time the heartbeat LED should also start blinking red.

7. Wait two minutes and confirm detector LED status pointing normal operation. If detectors used with PPS Manager Panel, panel should recognise each detector correctly with their address. PPS Manager detector search period may take up to 5 minutes.
8. Switch Off the external power to the detector.
9. Fit the cover and make sure none of the cables cause an obstruction while fitting cover
10. Switch on external power to the detector.

## Calibration

It is recommended to periodically carry out calibration to ensure correct operation. Calibration should be done by a person who trained and certified by local or international authorities.

Prosense detector calibration includes two steps which are zero and span calibration. During the calibration both steps have to be completed. It is possible to perform only zero calibration if necessary. It is mandatory to perform first zero calibration to perform span calibration. Detector should be powered and stabilized for at least 30 minutes before calibration. Zero calibration should be done by clean air. Span calibration should be done by specific gas combinations and levels depending of the detector and sensor type. Please check table below:

Detector	Calibration gas level
CO	150 ppm (balance air or N2)
NO2	5 ppm (balance air or N2)

**Table 4: Calibration gas concentrations**

To calibrate the detector, use an appropriate span gas cylinder, constant flow regulator and Prosense Gas Cap. The flow rate used for calibration gas should be 0.5 L/min (30L/hour).

Calibration can be done by a computer with Prosense Gas Monitor software. To start calibration, first enable communication between detector and computer. The computer should be connected to detector with a serial cable that can able to communicate RS485. If computer uses USB ports, a suitable RS485 to USB converter should be used. The communication signals of the detector should be connected to A and B signals of the converter.

The detector must be powered externally with a 12V-24 VDC power supply after it is connected to the computer.

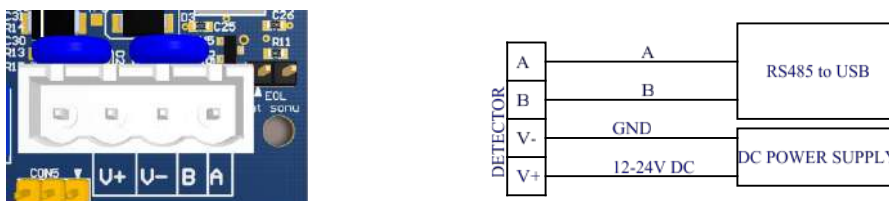

**Diagram 12: Connection between computer and detector**

Default Modbus slave address is set to 1 on program. If detector address is different exact address should be set on program to communicate to the detector.  
To initiate communication  
Open the SETUP menu. The settings will automatically come up on opened the screen by clicking “Refresh ports” button. Select COM then click OK

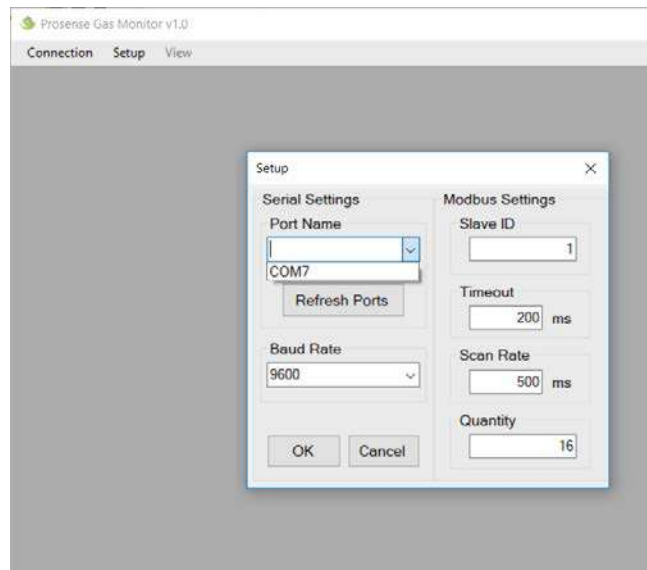

**Diagram 13: Connection setup**

Once address and serial port set, click Connection and click on START.



**Diagram 14: Start Connection**

The following Detector Data screen will be opened when START is pressed. The detector will stay WARM\_UP stage until warm-up period completed after power-on, and then detector status should be OK. The screen bar will show Connected message if program can able to communicate to the detector:

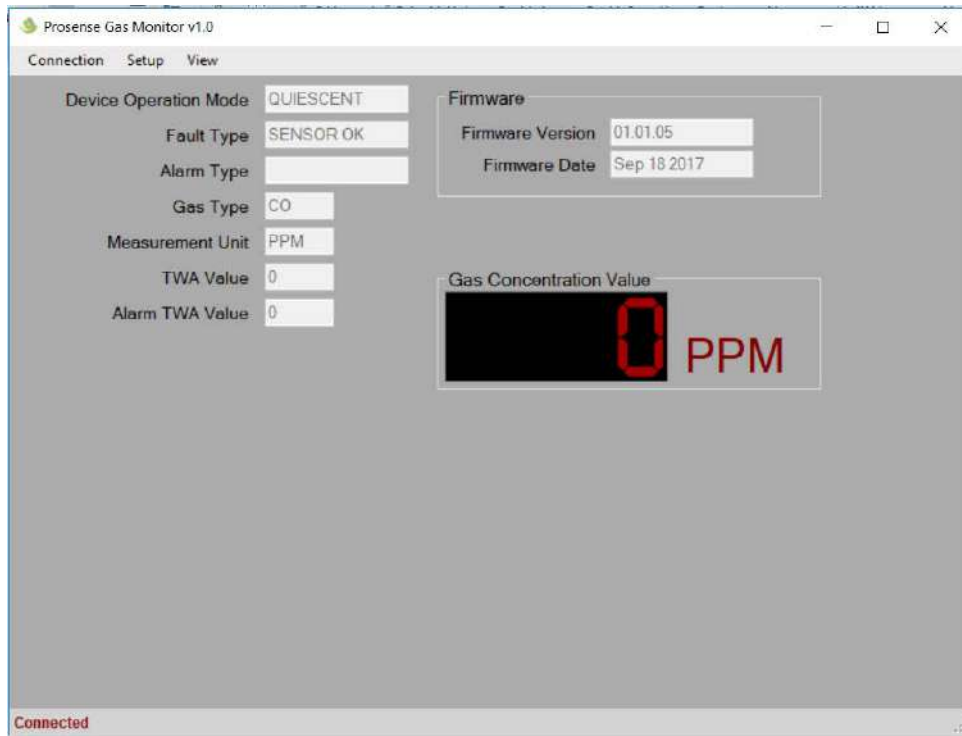

**Diagram 15: Detector parameters screen**

To start calibration, select View menu option and select Calibration. This option is not available when detector on fault status.

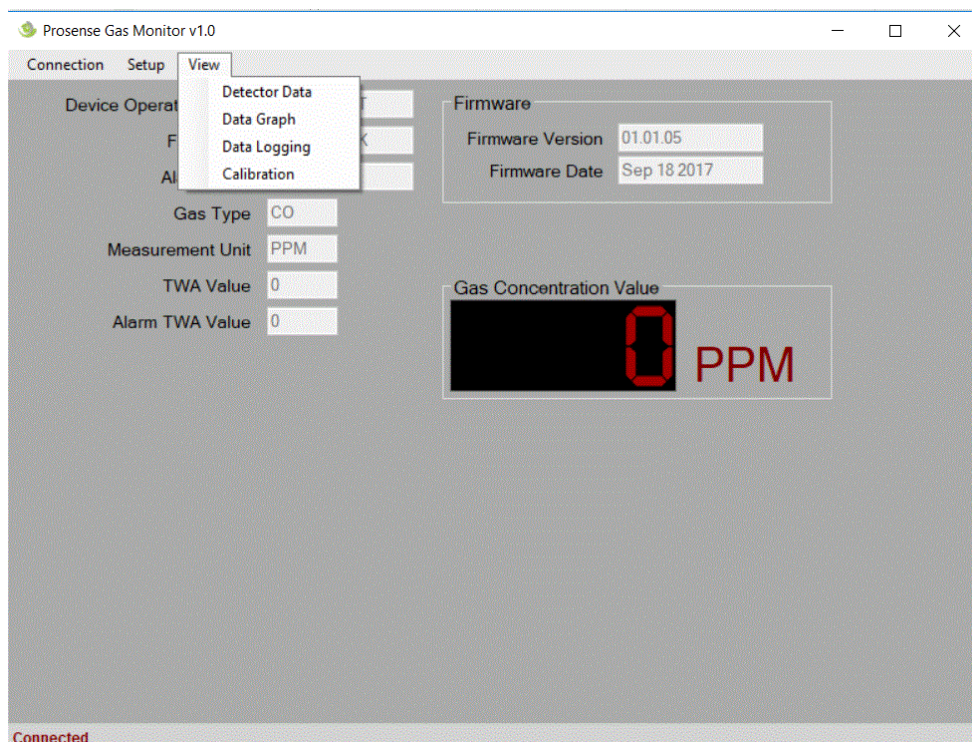

**Diagram 16: View Menu options**

A new screen will open to start calibration procedures:

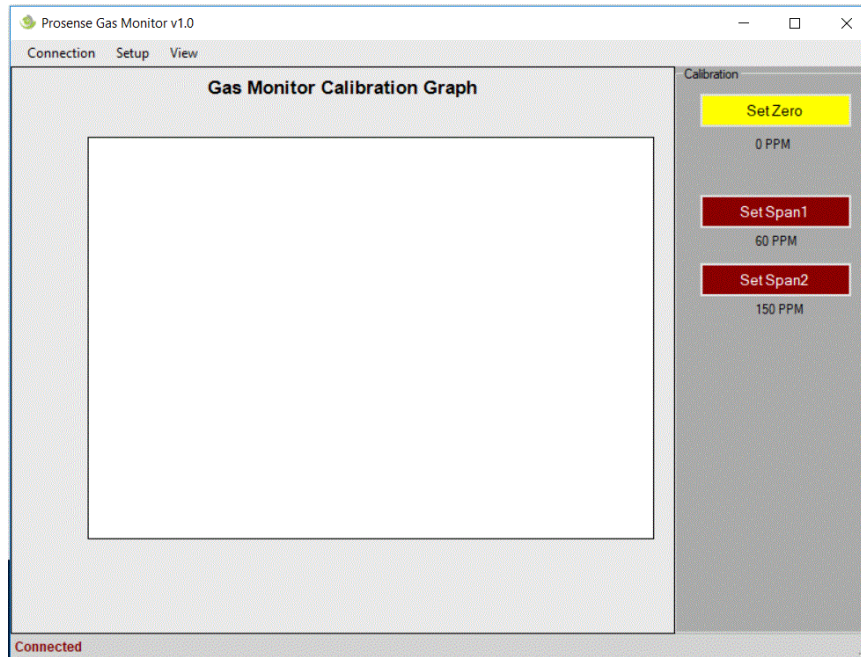

Diagram 17: Calibration screen

Follow the below steps to perform calibration.

### Zero Calibration

Detector should run at least an hour clean air condition before performing ZERO calibration.

1. Apply Clean Air (O<sub>2</sub>, 20,9 %Vol) for five minutes.
2. Press "SetZero" button and wait for 75 seconds without performing anything.
3. Zero offset calibration will be completed up on graphic stabilized.

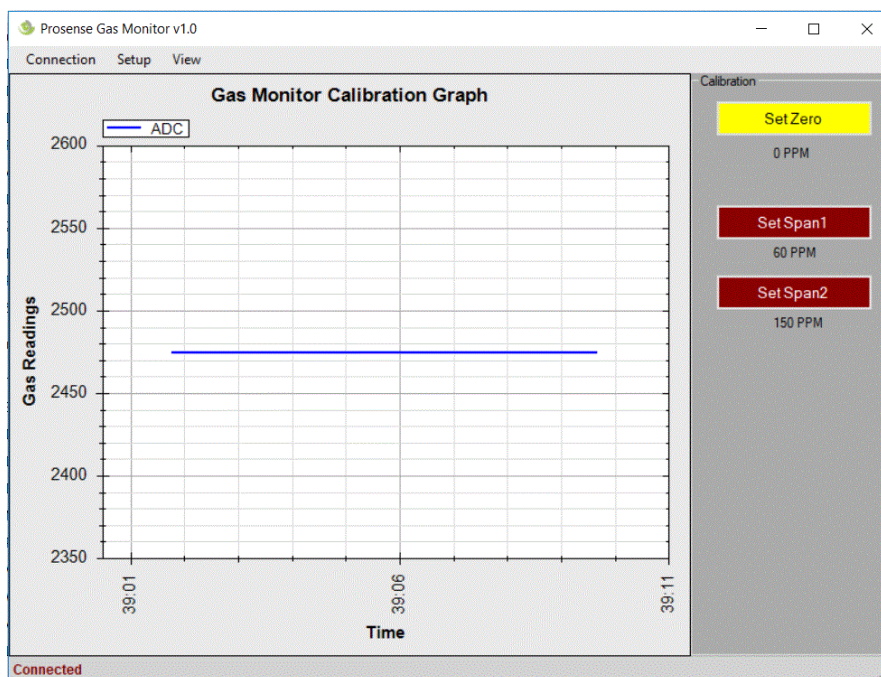

Diagram 18: Calibration screen and graph

## Span Calibration

Span calibration should be done while span gas applied to detector.

1. Apply span gas to detector for 5 minutes
2. Press "SetSpan2" button when graphic stabilized.
3. Wait 75 seconds
4. Span calibration will be completed up on graphic stabilized.

For more information please see the Prosense Gas Monitor software user guide.

## Maintenance

### Proactive Maintenance:

All gas detectors including both for flammable and toxic gases should have to pass a functional test and calibration every three to six months according to EN 60079-17 industrial standards. The test results and calibration reports should be recorded in maintenance books.

### Operational Life:

Typical life of a toxic gas sensor which made by electrochemical component is dependent on the application, frequency and amount of gas exposure. Under normal conditions toxic sensors used in PPS+ Series have an expected life equal to or greater than 60 months.

### Servicing

**Important:** All replacement actions (sensor, sinter and sensor head) shall be done by Prosense service personnel as it needs some special steps that should be performed in laboratory environment.

### Filter Replacement:

Due to environmental conditions the filter at sensor head might lose permeability that could have a negative impact on sensor performance. For example if the installation includes cement or similar dust, the filter would block the air/gas entry to sensor. The filter should be checked visually and replaced if necessary. To replace filter please follow the below procedure:

- 1- Power off the Prosense detector
- 2- Loosen the locking grub screw
- 3- Remove the sensor head cap via pressing the latches on both sides
- 4- Remove the dirty filter inside the sensor head cap
- 5- Install the clean filter inside the sensor head cap
- 6- Fix the sensor head cap to the sensor head via matching the latches to their holders
- 7- Fix the Locking grub screw

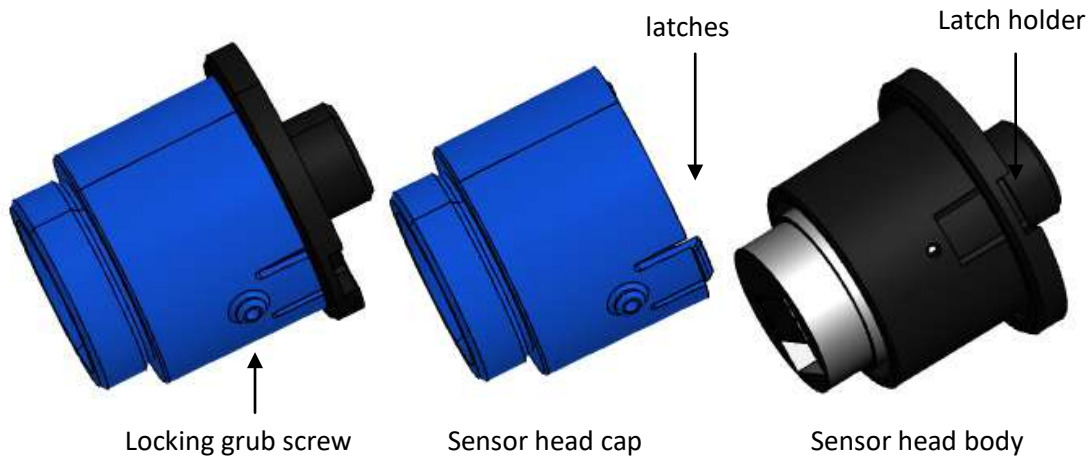
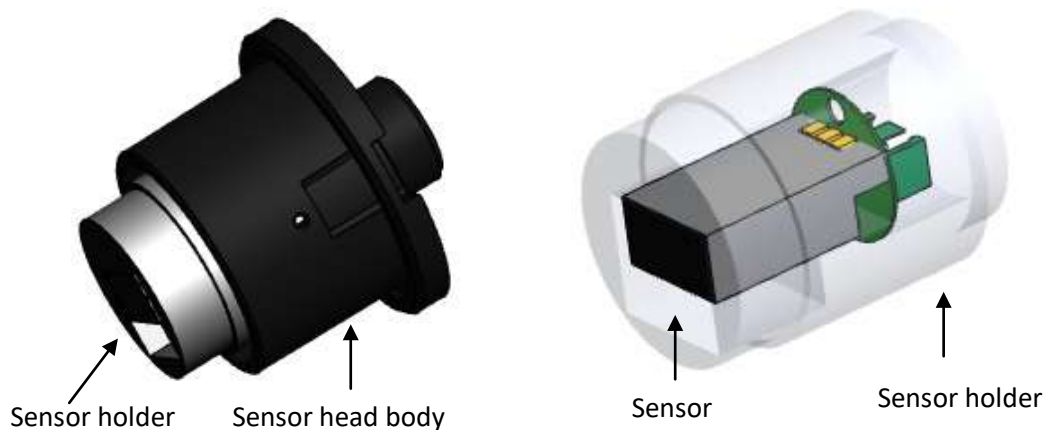

**Diagram 19: SH40 Sensor Head components**

### Sensor Replacement:

The electrochemical sensor used in CO and NO2 detectors should be replaced when they reached to their lifetime. The sensor is located its socket inside the sensor head.

- 1- Power of the Prosense detector
- 2- Loosen the locking grub screw
- 3- Remove the sensor head cap via pressing the latches on both side



**Diagram 20: SH40 Sensor Head and sensor holder**

- 4- Remove the old sensor from sensor holder inside the sensor head body
- 5- Install the new sensor to sensor holder inside the sensor head body
- 6- Fix the sensor head cap to the sensor head via matching the latches to their holders
- 7- Fix the Locking grub screw
- 8- Power-On Prosense detector
- 9- Leave detector working at least 4 hours in clean air environment

**Important:** It is necessary to perform detector calibration after sensor head replacement.

## Sensor Head Replacement:

Prosense sensor head is a separate part that can be replaced in the field. The sensor head includes integrated sensor, electronic device and sinter in it. To replace sensor head:

- 1- Power-Off the Prosense detector
- 2- Disconnect sensor cables from the detector main board
- 3- Remove the sensor head from the body
- 4- Install sensor head
- 5- Connect the sensor cables to detector main board
- 6- Power-On Prosense detector
- 7- Leave detector working at least 4 hours in clean air environment

**Important:** It is necessary to perform detector calibration after sensor head replacement.

## General specification

### PPS+ Series CO and NO2 Detector Electrical Specifications:

Input Voltage Range	12 to 24VDC (16VDC nominal)
Max Power Consumption	0.25 Watts
Terminals	4 x screw terminals suitable for wire diameter 1.5mm <sup>2</sup> to 2.5mm <sup>2</sup>
Communication	RS485, Modbus RTU
Sensor	Electrochemical

**Table 5: PPS+ Series CO and NO2 detectors electrical specifications**

### Detector Body Specifications:

Material	Plastic (grey)
Weight	Plastic junction box: 230g (with Sensor Header)
Mounting	Wall mounting
Entries	PG11

**Table 6: Detector body specifications**

### Environmental:

IP Rating	IP54 (plastic junction box)
Operating Temperature	-10°C to +50°C / 14°F to +120°F
Operating Humidity	Continuous 20-90%RH (non condensing)
Operating Pressure	90-110kPa
Storage Conditions	-10°C to +50°C (14°F to +120°F)

**Table 7: Environmental specifications**

# Certificate



Physical-Technical Testing Institute  
Ostrava – Radvanice

## Type Examination Certificate

about verification of electrical apparatus used for the detection and measurement of toxic and combustible gases in car parks and tunnels

Type Examination Certificate number:

**FTZÚ 18 E 0001**

Product: **Gas detector type PPS+CO**

Manufacturer: **PROSENSE TEKNOLOJİ SAN. LTD.ŞTİ**

Address: **Yukarı Mah. Harman Sokak No:42, Kartal - İstanbul, Turkey**

This product and any acceptable variation thereto is specified in the schedule to this certificate and the documents therein referred to.

The Physical-Technical Testing Institute, Certification Body No.3051, accredited by ČIA o.p.s, Prague according to EN ISO/IEC 17065:2012, certifies that this product has been found to comply with requirements of the following clauses of standard:

**clauses 1, 2, 3, 4.1, 4.2, 4.3, 5.2, 5.3, 5.4, 5.5, 6.1, 6.2, 6.3, 6.4, 6.5, 6.6, 6.7, 6.10, 6.12, 6.13, 6.14, 6.15, 6.17, 6.19 of the EN 50545-1:2011 + A1:2016**

Manufacturer listed in the certificate is responsible for product conformity assurance in accordance with its specification (documentation) listed in this certificate and for successful performance of all specified routine tests and verification.

This certificate relates only to the verification of electrical apparatus used for the electrical apparatus used for the detection and measurement of toxic and combustible gases in car parks and tunnels. Further requirements can be applied to the manufacturing process and supply of this product. These are not covered by this certificate.

This certificate is valid till: **25.10.2023**

Responsible person:

*o.p. Mělnudke*

Dipl. Ing. Lukáš Martinák  
Head of certification body



Date of issue: 25.10.2018

Page: 1/2

This certificate is valid only for products described in this certificate and doesn't replace any other documents. This certificate shall not be reproduced except in full without written approval of authorized entity (FTZÚ).

Physical-Technical Testing Institute, s.p., Píkářská 1337/7, 716 07 Ostrava - Radvanice, Czech Republic  
tel +420 595 223 111, fax +420 596 232 672, ftzu@ftzu.cz, www.ftzu.cz



Physical-Technical Testing Institute  
Ostrava – Radvanice

Schedule

Type Examination Certificate No. FTZÚ 18 E 0001

Description of product:

The product is a fixed mounting, remote gas detector with RS485 interface and 24VDC power. The product is used for detection of the gas carbone monoxide CO in the car parks and tunnels.

The product consists of one plastic enclosure with one cable gland and one mounted cylinder with the sensing element. The product includes one LED for power state indication. The access of gas to the sensing element is done through a filter by diffusion process. The internal sensing element has electrochemical principle.

The performance tests have been carried out on the product in the conditions mentioned below:

Conditions: Temperature range: -10 to +40°C  
Humidity range: 5 to 95 % RH  
Gas range: 0 to 300 ppm v/v  
Nominal voltage range: 12 to 24 VDC  
Calibration flow: 20 to 30 litres/hour  
Interfaces: RS485

The software, construction, label, marking and instruction requirements have not been evaluated and it is not covered by this certificate.

Test report No.: 18E/0001

List of support documentation:

Name:	Sheets:	Issue:	Date:
User Manual	25	01	10.2018
Leaflet PPS-CO	2	-	01.2018
Circuit diagram	4	v1.2	03.01.2018
Layout PCB	1	-	01.2018

Responsible person:

  
Dipl. Ing. Lukáš Martinák  
Head of certification body



Date of issue: 25.10.2018

Page: 2/2

This certificate is valid only for products described in this certificate and doesn't replace any other documents.  
This certificate shall not be reproduced except in full without written approval of authorized entity (FTZÚ).

Physical-Technical Testing Institute, s.p., Pikartská 1337/7, 716 07 Ostrava - Radvanice, Czech Republic  
tel +420 595 223 111, fax +420 596 232 672, ftzu@ftzu.cz, www.ftzu.cz

## Declaration



### Manufacturer Declaration of Conformity



Prosense Teknoloji San Ltd. Şti declares the PPS+ Series products to be in accordance with the following standards and directives.

Name and address of Manufacturer: **Prosense Teknoloji San Ltd Şti**  
**Cumhuriyet Mah, Mermer Sk. No:16**  
**34876 Kartal – İstanbul – Türkiye**

Description of Devices: **PPS+ Series Fixed Type Gas Detectors**

Applied Harmonized international standards:

**EN 50545-1:2011 + A1:2016** Electrical apparatus for the detection and measurement of toxic and combustible gases in car parks and tunnels. General performance requirements and test methods for the detection and measurement of carbon monoxide and nitrogen oxides

Applied European Directives:

2014 / 30 / EU Electromagnetic Compatibility (EMC)

Each PPS+ Series gas detector device which Production Quality Assurance procedures and Type Examination procedures have been applied has been shown to conform to an approved Type and to the applicable classification rules and essential principles before being supplied. This declaration is being made on the basis of the following certificates:

*Production Quality Assurance Certificate: ExVeritas 18PQAN0072*

*Type Examination Certificate: FTZU 18E001*

Authorised Signatory: **Firat Celep**  
Production Manager

Date: **06.02.2020**

## Warranty statement

All products are designed and manufactured to the latest internationally recognized standards by Prosense Technology under a Quality Management system that is certified to ISO 9001. As such Prosense Technology warrants its products against defective parts and workmanship and will repair or (at its option) replace any instruments which are or may become defective under proper use within 12 months from date of commissioning by an approved Prosense Technology representative or 18 months from date of shipment from Prosense Technology, whichever is the sooner. This warranty does not cover disposable batteries or damage caused by accident, abuse, abnormal operating conditions or poisoning of sensor.

Defective goods must be returned to Prosense Technology premises accompanied by a detailed description of any issue. Where return of goods is not practicable Prosense Technology reserves the right to charge for any site attendance where any fault is not found on the equipment. Prosense Technology shall not be liable for any loss or damage whatsoever or howsoever occasioned which may be a direct or indirect result of the use or operation of the Contract Goods by the Buyer or any Party.

This warranty covers instrument and parts sold to the Buyer only by authorized distributors, dealers and representatives as appointed by Prosense Technology. The warranties set out in this clause are not pro rata, i.e. the initial warranty period is not extended by virtue of any works carried out there under.

In no event will Prosense Technology be liable for any incidental damages, consequential damages, special damages, punitive damages, statutory damages, indirect damages, loss of profits, loss of revenues, or loss of use, even if informed of the possibility of such damages. Prosense Technology's liability for any claims arising out of or related to this product will in no case exceed the order value. To the extent permitted by applicable law, these limitations and exclusions will apply regardless of whether liability arises from breach of contract, warranty, tort (including but not limited to negligence), by operation of law, or otherwise.